

HITACHI AIR-COOLED WATER CHILLERS – SCREW TYPE –

Nominal Capacity Range

AZY1: 158kW to 1,590kW

AZPY1: 160kW to 1,602kW



Technical Catalog I Design Information

Models:

RCUF45AZY1	RCUF45AZPY1
RCUF50AZY1	RCUF50AZPY1
RCUF60AZY1	RCUF60AZPY1
RCUF90AZY1	RCUF90AZPY1
RCUF100AZY1	RCUF100AZPY1
RCUF120AZY1	RCUF120AZPY1
RCUF150AZY1	RCUF135AZPY1
RCUF180AZY1	RCUF150AZPY1
RCUF200AZY1	RCUF180AZPY1
RCUF220AZY1	RCUF200AZPY1
RCUF240AZY1	RCUF240AZPY1
RCUF270AZY1	RCUF270AZPY1
RCUF300AZY1	RCUF300AZPY1
RCUF330AZY1	RCUF320AZPY1
RCUF360AZY1	RCUF360AZPY1
RCUF400AZY1	RCUF405AZPY1
RCUF420AZY1	RCUF420AZPY1
RCUF450AZY1	RCUF450AZPY1

New Series! This series of HITACHI air-cooled water chillers up to 450RT has been developed for various requirements of air-conditioning systems and industrial chilled water systems, where these equipment are operated under high ambient temperatures of 43°C, Therefore, the units can be utilized under a wide temperature range.

These water chillers has utilized the most advanced Hitachi R134a refrigerant special semi-hermetic twin-screw compressor, featuring high reliability, low noise and low vibration, and highly efficient air-cooled condenser, resulting in compact design.

The unit is composed of compressors, air-cooled condensers, shell-tube type water coolers, and other auxiliary and control devices, compactly packaged in a weather-proof cabinet which is constructed of galvanized steel plates processed with specially baked resin paint.

TABLE OF CONTENTS

1.Features.....	2
2.General Data.....	5
3.Dimensions Data.....	9
4.Operation Space.....	16
5.Center of Gravity.....	18
6.Weight Balance.....	18
7.Recommended Concrete Curbs.....	20
8.Selection Example.....	26
9.Cooling Capacities.....	27
10.Electrical Data.....	39
11.Sound Data.....	41
12.Working Range.....	42
13.Component Detailed Data.....	44
14.Safety and Control Devices Setting.....	49
15.Electrical Wiring Diagram.....	51
16.DIP Switch Setting.....	56

1.Features

1.1 Features

Unit - The unit shall be an air-cooled screw type water chiller with R134a refrigerant, and shall be factory-completed with screw-type compressors, refrigeration cycle(s), air-cooled condensers, shell-and-tube water coolers, condenser fan motors, a star-delta starter, protective and safety devices, Electronic expansive valves and compressor discharge stop valves, and shall be factory-assembled, piped, internal wired and charged with R134a refrigerant. The unit shall be completely weather-proofed for outdoor installation. The unit shall comply with Chinese Industrial Standards and other Chinese Industrial Standardization statutes, including safety codes.

Capacity - The cooling capacity of the unit shall be _____kW or greater under the following conditions:
____m³/h chilled water flow rate,
____°C chilled water inlet temperature,
____°C chilled water outlet temperature,
_____m². °C/W fouling factor for the water-side heat exchanger or greater.
The water-side heat exchanger pressure decrease shall not exceed _____kPa.
The compressor power input shall not exceed _____kW under the prescribed conditions.

Power Supply - The unit shall operate on _____V, _____Hz, three-phase current, and shall be capable to operate within maximum _____V and minimum _____V.

Dimensions and Weight - The height of the unit shall be _____mm, the width shall be _____mm, and the depth shall be _____mm. The weight of the unit shall not exceed _____kg.

Cabinet - The cabinet shall be constructed of galvanized steel, baked with synthetic resin paint. The service panels shall be easily removable for service access to the electrical components such as magnetic switches and electrical devices.

Compressor - The compressor shall be a semi-hermetic compressor from the same manufacturer. The compressor shall be serviceable type. The compressor protection system shall include an overcurrent relay, a pressure switch, a timer relay and an internal thermostat embedded in the motor winding.

Water-Cooler - the water cooler shall be the dry expansion type with a horizontal welded steel construction shell, containing inside tubes. The refrigerant side of the water cooler shall be cleaned, dehydrated and tested for leakage at the maximum permissible working pressure of _ MPa. The water side of the water cooler shall be cleaned and performed water pressure test at_ MPa.

Air-Side Heat Exchanger Fan and Fan Motor - The fan shall be the propeller type directly driven by a _____kW motor. The motor shall be thermally protected from overloaded conditions with a thermal overcurrent relay and shall be permanently lubricated, The winding and bearing of the condenser fan motor shall be weather-proof construction.

Condenser - The condenser shall be the multi-pass, cross-finned tube type, equipped with aluminum slit fins, mechanically bonded to seamless, oxygen-free copper tubes. The condenser shall be cleaned, dehydrated and tested for leakage at the maximum permissible working pressure of _____ MPa.

Accessories - Standard accessories shall include vibration-proof mats, foundation bolts.

The Combination of HITACHI Screw Compressor and Microcomputer Inclines HITACHI Air-Cooled Chillers to be perfect

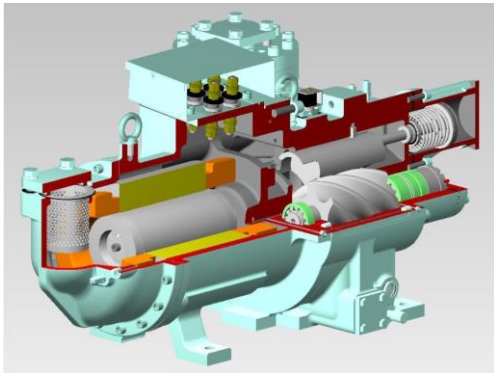

+

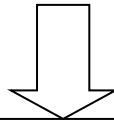
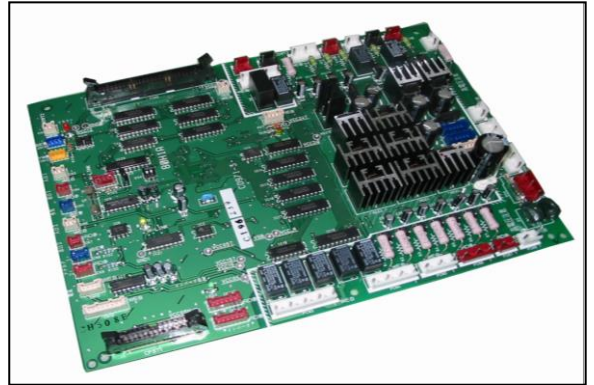

High Efficiency/Precise Temperature Control/Variety Functions

Various

The new model has been installed with microcomputer and can offer the functions as below:

- Independent warning hint
The independent warning, such as stopping operation in high pressure and low pressure can be shown on the controlling board via warning signal.
- Operations of converting compressors
The operation order of multiple compressors can be converted in order to balance the service hours of compressors. This function can help to lengthen life-span of the unit.
- Other functions
Besides above functions, the following devices are equipped:
Long distance/live switch, indicator of temperature of chilled water and the automatic starting after temporary electrical power cut.
- BMS communication function (Protocol converters as the optional components)



LCD(liquid crystal display) operative interface

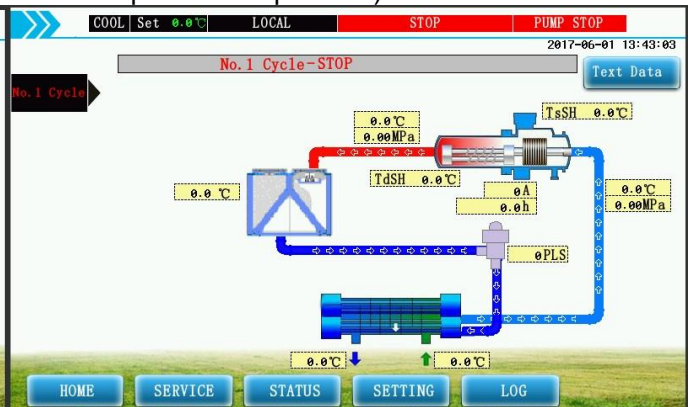

LCD(liquid crystal display) running and display interface

Lower Noise, Lower Vibration and Reliable Long Period Operation...

The Hitachi Screw Water Chiller Can Meet Your Requirements!!

The most advanced Hitachi G Style Semi-hermetic screw compressor

G style semi-hermetic screw compressor has the features of simple structure, quiet operation and long service life.

A Symmetrical Rotor Profile and Other Features

This profile of the compressor rotor, 4:6 (male and female) type, assures excellent efficiency even in high compression ranges, in addition to these uniquely-profile rotors, the following features are incorporated. Use of special bearing, resulting in long life and high reliability. Patented capacity control system, enabling simple control system. High precision and high-grade finishing rotors, enabling no oil-cooling system

Easy for Maintenance

Equipped with accessibility components such as Pressure Relief Valve and Oil Sight Glass, easy maintenance is obtained.

Single power supply

The unit has two compressors only needs one power supply. This kind of system can reduce the cost of power supply spent by users.

Factory-Charged

The cooling cycle is charging refrigerant under the circumstance of rigid quality control and is enclosed. Therefore, it can be installed and operate within a short time.

Factory-Wires

Only power wiring and water piping are required in the field.

Most Reliable Protective and Ancillary Components

The units are protected against any assumed failure of operation, based on the following components: Electronic Timer for Compressors, Three-Phase Quick Response Over current Relay, Internal Thermostats for Compressor Motors, Freeze Protection Thermostats. Pressure Relief Valve, Oil Sight Glass, Oil Heater and Reverse-Phase Protection Relays for Compressors.

Standard Accessories

The following accessories are supplied with the unit

- a. Vibration-Proof Rubber Mats
- b. Acoustic panel for compressor
- c. Water connection companion flange
- d. Spreader bar for rigging

Other optional accessories

The following accessories are optional, Please get in touch with HITACHI or HITACHI distributor if required:

Protocol converter that connects with the building automation system (Modbus RTU protocol option)

2. General Data

AZY1 series

Model		R134a	RCUF45 AZY1	RCUF50 AZY1	RCUF60 AZY1	RCUF90 AZY1	RCUF100 AZY1	RCUF120 AZY1	RCUF150 AZY1	RCUF180 AZY1	RCUF200 AZY1	RCUF220 AZY1	
Nominal Cooling Capacity ¹		kW	158	175	215	316	351	440	530	645	702	791	
		kcal/h	135,880	150,500	184,900	271,760	301,860	378,400	455,800	554,700	603,720	680,260	
		RT	45	50	61	90	100	125	151	183	200	225	
Capacity Control		—	Continuous Capacity Control										
		%	100~25, 0										
Outer Dimension	Depth	mm	2,390			4,490			6,590		9,080		
	Width	mm	2,060			2,060			2,060		2,060		
	Height	mm	2,120			2,160			2,200		2,160		
Net Weight		kg	1,550	1,600	1,710	2,900	3,000	3,220	4,650	4,880	3000x2	3220+3000	
Refrigerant	Standard	—	R134a										
	Flow Control	—	Electronic expansive valve										
	Number of Circuit	—	1			2			3		4		
Compressor	Type	—	Semi-Hermetic Screw Type(R134a only)										
	Model	ASCCW- **ZG	50	50	60	50	50	60	50	60	50	50+60	
	Quantity	—	1			2			3		4		
Heat-Exchanger	Condenser		Cross Fin Type										
	Fan Motor	Condenser Fan	Direct drive Propeller Fan										
		Power Input	kW	1.1	1.1	1.1	1.1	1.1	1.1	1.1	1.1	1.1	1.1
		Quantity	—	4	4	4	8	8	8	12	12	16	16
		Air Dis-charge	m ³ /min	930	930	930	1,860	1,860	1,860	2,790	2,790	3,720	3,720
Evaporator		—	Shell and Tube Type										
Safety Devices		—	Three-Phase Over current Relay, High-Pressure Switch, High and Low-Pressure Control, Oil Heater, Internal Thermostat for Compressor Motor, Freeze Protection Control, Reverse Phase Protection Control, Discharge Gas Overheat Protection, Compressor frequent ON/OFF control and Pressure Relief Valve.										
Piping Connections for Water-Side Heat Exchanger(Inlet/Outlet)		—	With DN80 Flange				With DN125 Flange						
Shipping Weight ²		kg	1,590	1,640	1,750	2,940	3,040	3,260	4,690	4,920	3,040x2	3,260+3,040	
Shipping Dimension	Depth	mm	2,410	2,410	2,410	4,510	4,510	4,510	6,610	6,610	4,510x2	4,510x2	
	Width	mm	2,080	2,080	2,080	2,080	2,080	2,080	2,080	2,080	2,080	2,080	
	Height	mm	2,150	2,150	2,150	2,190	2,190	2,190	2,230	2,230	2,190	2,190	
power input		kW	48.5	53.7	66.0	96.9	107.7	135.0	162.6	197.9	215.3	242.6	

Notes

- The nominal cooling capacities are based on GB/T 18430.1-2015(*1)
Chilled Water Outlet Temperature /Nominal water flow: 7 °C / 0.172 m³ / (h·kW)
Condenser Air Inlet Temperature: 35 °C (DB)
- Applicable Power Supply
Main Power Source: (AC3φ) 380/415V, 50Hz
Control Power Source: (AC1φ) 220/240V, 50Hz
- The units greater than 200AZY1 including 200AZY1 consist of two or three modules and are separately shipped. (*2).
- The common chilled water piping (Filed-Supplied) between each water cooler shall be directly connected at site.

Working Range

Item	Standard
Chilled Water Outlet Temperature	5~15°C
Condenser Air Inlet Temperature(DB)	5~43°C

5. Water Flow

- RCUF200,240,300,360,450AZY1

It is necessary to control the common water flow volume to each cooler.

- RCUF220,270,330,400,420AZY1

Because the chilled water flow rate is different between No.1 No.2 and No.3 units, it is necessary to control the water flow volume of each unit with adjusting valves (Filed-Supplied).

- It is required to connect electrical control wires between No.1, No.2 and No.3 units for the unit greater than 200AZY1 including 200AZY1.

- The nominal pressure of water pipe flange is PN1.6MPa.

AZY1 series

Model		R134a	RCUF240 AZY1	RCUF270 AZY1	RCUF300 AZY1	RCUF330 AZY1	RCUF360 AZY1	RCUF400 AZY1	RCUF420 AZY1	RCUF450 AZY1	
Nominal Cooling Capacity ¹		kW	880	970	1060	1175	1290	1411	1,500	1590	
		kcal/h	756,800	834,200	911,600	1,010,500	1,109,400	1,213,460	1,290,000	1,367,400	
		RT	250	276	301	334	367	401	426	452	
Capacity Control		—	Continuous Capacity Control								
		%	100~25. 0								
Outer Dimension	Depth	mm	9,080	11,180	13,280			18,670		20,770	
	Width	mm	2,060	2,060	2,060			2,060		2,060	
	Height	mm	2,160	2,200	2,200			2,200		2,200	
Net Weight		kg	3220x2	4650+3220	4650x2	4880+4650	4880x2	4650x2+3000	4650x2+3220	4650x3	
Refrigerant	Standard	—	R134a								
	Flow Control	—	Electronic expansive valve								
	Number of Circuit	—	4	5	6			8		9	
Compressor	Type	—	Semi-Hermetic Screw Type(R134a only)								
	Model	ASCCW- **ZG	50	50+60	50	50+60	60	50	50+60	50	
	Quantity	—	4	5	6			8		9	
Heat-Exchanger	Condenser		—	Cross Fin Type							
	Fan Motor	Condenser Fan	—	Direct drive Propeller Fan							
		Power Input	kW	1.1	1.1	1.1	1.1	1.1	1.1	1.1	1.1
		Quantity	—	16	20	24	24	24	32	32	36
		Air Dis-charge	m ³ /min	3,720	4,650	5,580	5,580	5,580	7,440	7,440	8,370
Evaporator		—	Shell and Tube Type								
Safety Devices		—	Three-Phase Over current Relay, High-Pressure Switch, High and Low-Pressure Control, Oil Heater, Internal Thermostat for Compressor Motor, Freeze Protection Control, Reverse Phase Protection Control, Discharge Gas Overheat Protection, Compressor frequent ON/OFF control and Pressure Relief Valve.								
Piping Connections for Water-Side Heat Exchanger(Inlet/Outlet)		—	With DN125 Flange								
Shipping Weight ²		kg	3,260x2	4,690+3,260	4,690x2	4,920+4,690	4,920x2	4,690x2+3,040	4,690x2+3,260	4,690x3	
Shipping Dimension	Depth	mm	4,510x2	6,610+4,510	6,610x2	6,610x2	6,610x2	6,610x2+4,510	6,610x2+4,510	6,610x3	
	Width	mm	2,080	2,080	2,080	2,080	2,080	2,080	2,080	2,080	
	Height	mm	2,190	2,230	2,230	2,230	2,230	2,230	2,230	2,230	
power input		kW	269.9	297.5	325.2	360.4	395.7	432.8	460.1	487.7	

Notes

- The nominal cooling capacities are based on GB/T 18430.1-2015(*1)
Chilled Water Outlet Temperature /Nominal water flow: 7 °C / 0.172 m³ / (h·kW)
Condenser Air Inlet Temperature: 35 °C (DB)
- Applicable Power Supply
Main Power Source: (AC3φ) 380/415V, 50Hz
Control Power Source: (AC1φ) 220/240V, 50Hz
- The units greater than 200AZY1 including 200AZY1 consist of two or three modules and are separately shipped. (*2).
- The common chilled water piping (Filed-Supplied) between each water cooler shall be directly connected at site.

Working Range

Item	Standard
Chilled Water Outlet Temperature	5~15°C
Condenser Air Inlet Temperature(DB)	5~43°C

5. Water Flow

- RCUF200,240,300,360,450AZY1

It is necessary to control the common water flow volume to each cooler.

- RCUF220,270,330,400,420AZY1

Because the chilled water flow rate is different between No.1 No.2 and No.3 units, it is necessary to control the water flow volume of each unit with adjusting valves (Filed-Supplied).

- It is required to connect electrical control wires between No.1, No.2 and No.3 units for the unit greater than 200AZY1 including 200AZY1.

- The nominal pressure of water pipe flange is PN1.6MPa.

AZPY1 series

Model		R134a	RCUF45 AZPY1	RCUF50 AZPY1	RCUF60 AZPY1	RCUF90 AZPY1	RCUF100 AZPY1	RCUF120 AZPY1	RCUF135 AZPY1	RCUF150 AZPY1	RCUF180 AZPY1	RCUF200 AZPY1	
Nominal Cooling Capacity ¹		kW	160	178	215	320	356	430	480	534	640	712	
		kcal/h	137,600	153,080	184,900	275,200	306,160	369,800	412,800	459,240	550,400	612,320	
		RT	45	51	61	91	101	122	136	152	182	202	
Capacity Control		—	Continuous Capacity Control										
		%	100~25, 0										
Outer Dimension	Depth	mm	2,390		3,300	4,490		6310	6,590		9,080		
	Width	mm	2,060		2,060	2,060		2060	2,060		2,060		
	Height	mm	2,120		2,120	2,160		2200	2,200		2,160		
Net Weight		kg	1,600	1,700	2,000	2,950	3,150	3,750	4,500	4,700	2,950x2	3,150x2	
Refrigerant	Standard	—	R134a										
	Flow Control	—	Electronic expansive valve										
	Number of Circuit	—	1			2			3		4		
Compressor	Type	—	Semi-Hermetic Screw Type(R134a only)										
	Model	ASCCW- **ZG	50	50	60	50	50	60	50	50	50	50	
	Quantity	—	1			2			3		4		
Heat-Exchanger	Condenser		—	Cross Fin Type									
	Fan Motor	Condenser Fan	—	Direct drive Propeller Fan									
		Power Input	kW	1.1	1.1	1.1	1.1	1.1	1.1	1.1	1.1	1.1	1.1
		Quantity	—	4	4	6	8	8	12	12	12	16	16
		Air Dis-charge	m ³ /min	930	930	1,395	1,860	1,860	2,790	2,790	2,790	3,720	3,720
Evaporator		—	Shell and Tube Type										
Safety Devices		—	Three-Phase Over current Relay, High-Pressure Switch, High and Low-Pressure Control, Oil Heater, Internal Thermostat for Compressor Motor, Freeze Protection Control, Reverse Phase Protection Control, Discharge Gas Overheat Protection, Compressor frequent ON/OFF control and Pressure Relief Valve.										
Piping Connections for Water-Side Heat Exchanger(Inlet/Outlet)		—	With DN80 Flange				With DN125 Flange						
Shipping Weight ²		kg	1,640	1,740	2,040	2,990	3,190	3,790	4,540	4,740	2,990x2	3,190x2	
Shipping Dimension	Depth	mm	2,410	2,410	3,320	4,510	4,510	6,330	6,610	6,610	4,510x2	4,510x2	
	Width	mm	2,080	2,080	2,080	2,080	2,080	2,080	2,080	2,080	2,080	2,080	
	Height	mm	2,150	2,150	2,150	2,190	2,190	2,230	2,230	2,230	2,190	2,190	
power input		kW	45.6	50.7	61.3	91.2	101.4	122.5	136.8	152.1	182.3	202.8	

Notes

- The nominal cooling capacities are based on GB/T 18430.1-2015(*1)
Chilled Water Outlet Temperature /Nominal water flow: 7 °C / 0.172 m³ / (h·kW)
Condenser Air Inlet Temperature: 35 °C (DB)
- Applicable Power Supply
Main Power Source: (AC3φ) 380/415V, 50Hz
Control Power Source: (AC1φ) 220/240V, 50Hz
- The units greater than 180AZPY1 including 180AZPY1 consist of two or three modules and are separately shipped. (*2).
- The common chilled water piping (Filed-Supplied) between each water cooler shall be directly connected at site.

Working Range

Item	Standard
Chilled Water Outlet Temperature	5~15°C
Condenser Air Inlet Temperature(DB)	5~43°C

5. Water Flow

- RCUF180,200,240,270,300,360,405,450AZPY1
It is necessary to control the common water flow volume to each cooler.
- RCUF320,420AZPY1
Because the chilled water flow rate is different between No.1 No.2 and No.3 units, it is necessary to control the water flow volume of each unit with adjusting valves (Filed-Supplied).
- It is required to connect electrical control wires between No.1, No.2 and No.3 units for the unit greater than 180AZPY1 including 180AZPY1.
- The nominal pressure of water pipe flange is PN1.6MPa.

AZPY1 series

Model		R134a	RCUF240 AZPY1	RCUF270 AZPY1	RCUF300 AZPY1	RCUF320 AZPY1	RCUF360 AZPY1	RCUF405 AZPY1	RCUF420 AZPY1	RCUF450 AZPY1	
Nominal Cooling Capacity ¹		kW	860	960	1068	1142	1290	1440	1,494	1602	
		kcal/h	739,600	825,600	918,480	982,120	1,109,400	1,238,400	1,284,840	1,377,720	
		RT	245	273	304	325	367	409	425	456	
Capacity Control		—	Continuous Capacity Control								
		%	100~25, 0								
Outer Dimension	Depth	mm	12,720	13,280		16,290	19,930	20,770			
	Width	mm	2,060	2,060		2,060	2,060	2,060			
	Height	mm	2,200	2,200		2,200	2,200	2,200			
Net Weight		kg	3,750x2	4,500x2	4,700x2	3,150x2+3,750	3,750x3	4,500x3	4,700+4,500x2	4,700x3	
Refrigerant	Standard	—	R134a								
	Flow Control	—	Electronic expansive valve								
	Number of Circuit	—	4	6				9			
Compressor	Type	—	Semi-Hermetic Screw Type(R134a only)								
	Model	ASCCW- **ZG	60	50	50	50+60	60	50	50	50	
	Quantity	—	4	6				9			
Heat-Exchanger	Condenser		—	Cross Fin Type							
	Fan Motor	Condenser Fan	—	Direct drive Propeller Fan							
		Power Input	kW	1.1	1.1	1.1	1.1	1.1	1.1	1.1	1.1
		Quantity	—	24	24	24	28	36	36	36	36
		Air Dis-charge	m ³ /min	5,580	5,580	5,580	6,510	8,370	8,370	8,370	8,370
Evaporator		—	Shell and Tube Type								
Safety Devices		—	Three-Phase Over current Relay, High-Pressure Switch, High and Low-Pressure Control, Oil Heater, Internal Thermostat for Compressor Motor, Freeze Protection Control, Reverse Phase Protection Control, Discharge Gas Overheat Protection, Compressor frequent ON/OFF control and Pressure Relief Valve.								
Piping Connections for Water-Side Heat Exchanger(Inlet/Outlet)		—	With DN125 Flange								
Shipping Weight ²		kg	3,790x2	4,540x2	4,740x2	3,190x2+3,790	3,790x3	4,540x3	4,740+4,540x2	4,740x3	
Shipping Dimension	Depth	mm	6,330x2	6,610x2	6,610x2	4,510x2+6,330	6,330x3	6,610x3	6,610x3	6,610x3	
	Width	mm	2,080	2,080	2,080	2,080	2,080	2,080	2,080	2,080	
	Height	mm	2,230	2,230	2,230	2,230	2,230	2,230	2,230	2,230	
power input		kW	245.0	273.5	304.3	325.4	367.5	410.3	425.6	456.4	

Notes

- The nominal cooling capacities are based on GB/T 18430.1-2015(*1)
Chilled Water Outlet Temperature /Nominal water flow: 7 °C / 0.172 m³ / (h·kW)
Condenser Air Inlet Temperature: 35 °C (DB)
- Applicable Power Supply
Main Power Source: (AC3φ) 380/415V, 50Hz
Control Power Source: (AC1φ) 220/240V, 50Hz
- The units greater than 180AZPY1 including 180AZPY1 consist of two or three modules and are separately shipped. (*2).
- The common chilled water piping (Filed-Supplied) between each water cooler shall be directly connected at site.

Working Range

Item	Standard
Chilled Water Outlet Temperature	5~15°C
Condenser Air Inlet Temperature(DB)	5~43°C

5. Water Flow

- RCUF180,200,240,270,300,360,405,450AZPY1

It is necessary to control the common water flow volume to each cooler.

- RCUF320,420AZPY1

Because the chilled water flow rate is different between No.1 No.2 and No.3 units,it is necessary to control the water flow volume of each unit with adjusting valves (Filed-Supplied).

- It is required to connect electrical control wires between No.1, No.2 and No.3 units for the unit greater than 180AZPY1 including 180AZPY1.

- The nominal pressure of water pipe flange is PN1.6MPa.

3. Dimensions Data

RCUF45AZY1 / RCUF50AZY1

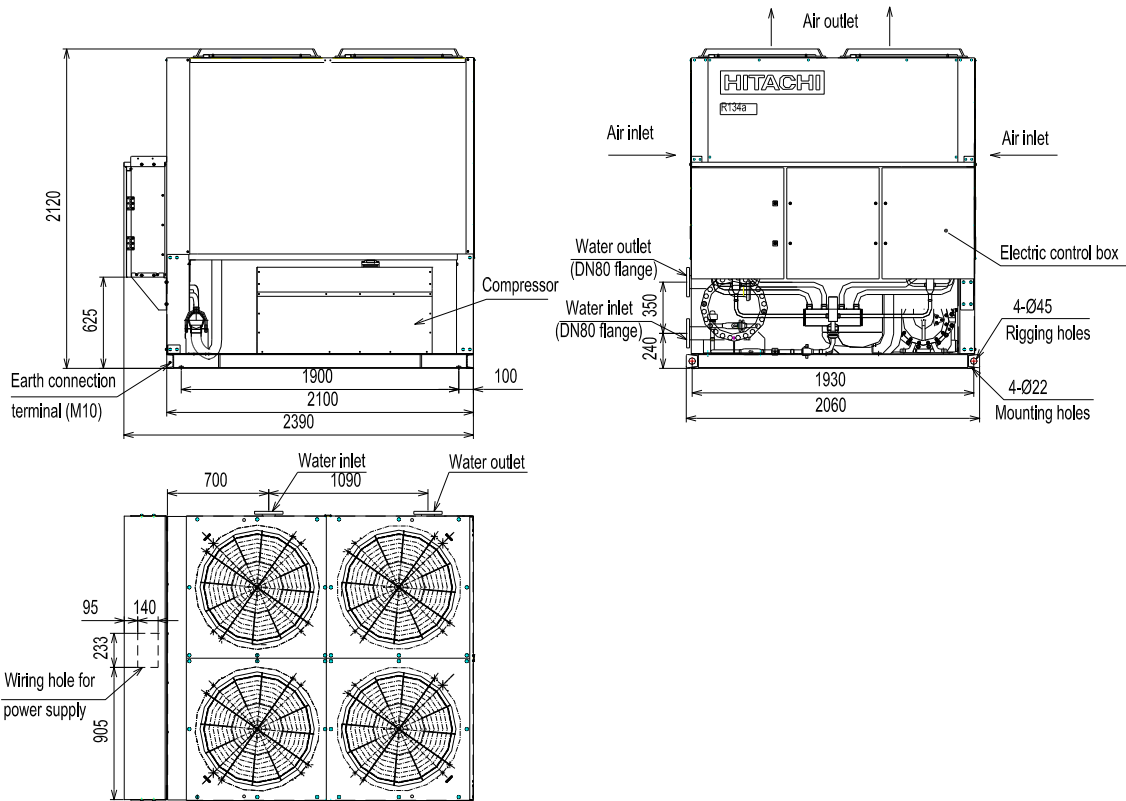

RCUF45AZPY1 / RCUF50AZPY1 / RCUF60AZY1

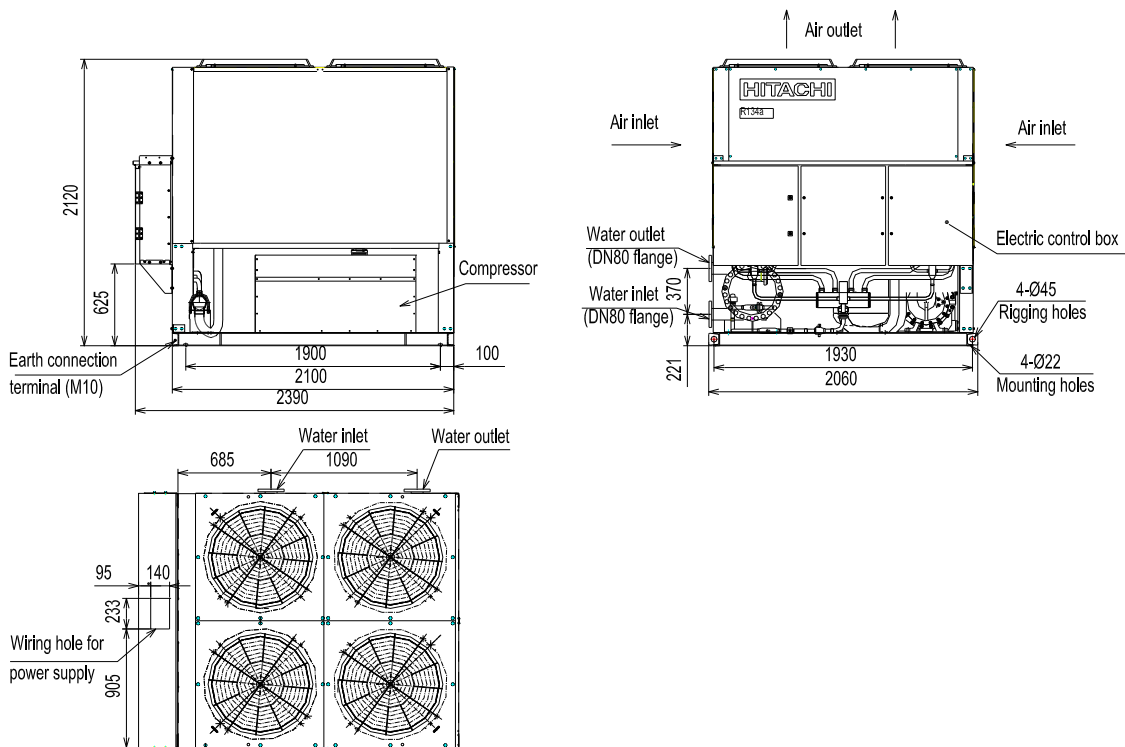

RCUF60AZPY1

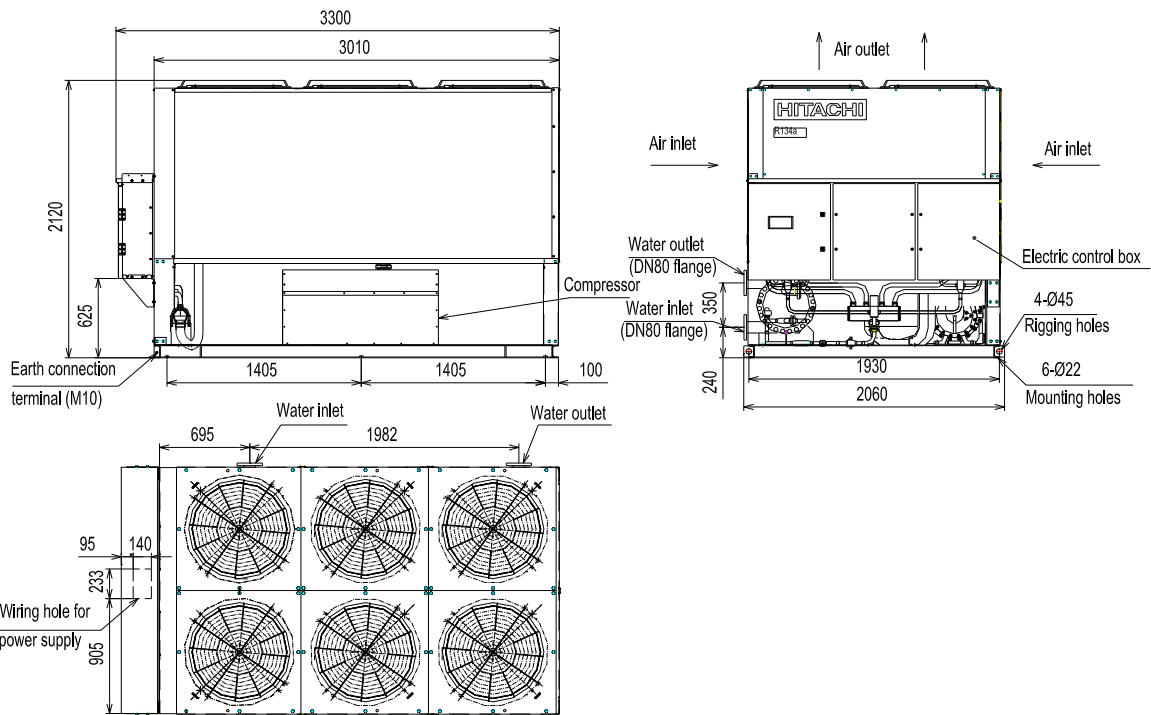

RCUF90AZY1 / RCUF100AZY1 / RCUF120AZY1 / RCUF90AZPY1 / RCUF100AZPY1

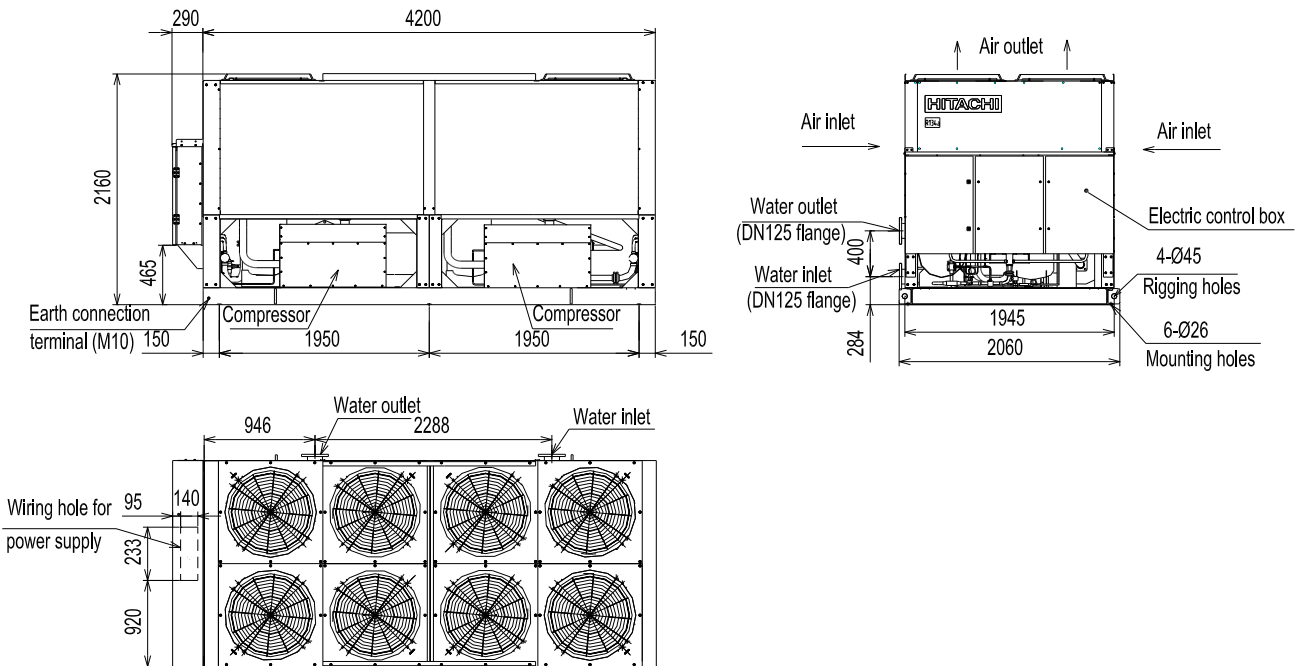

RCUF120AZPY1

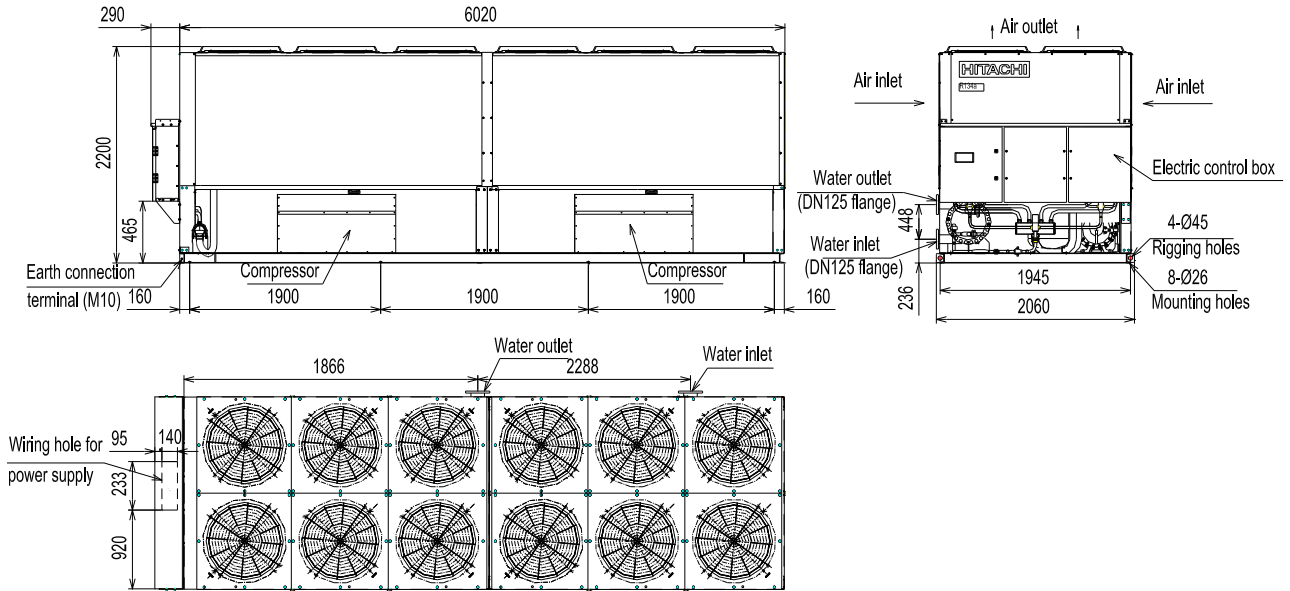

RCUF150AZY1 / RCUF180AZY1 / RCUF135AZPY1 / RCUF150AZPY1

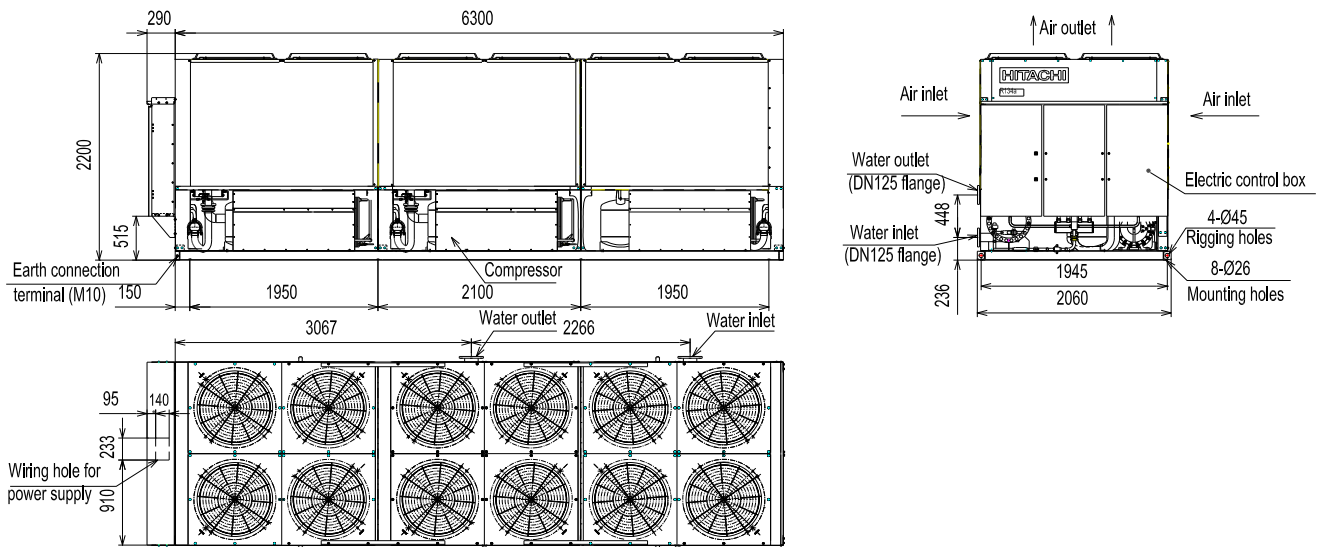

RCUF200AZY1 / RCUF220AZY1 / RCUF240AZY1 / RCUF180AZPY1 / RCUF200AZPY1

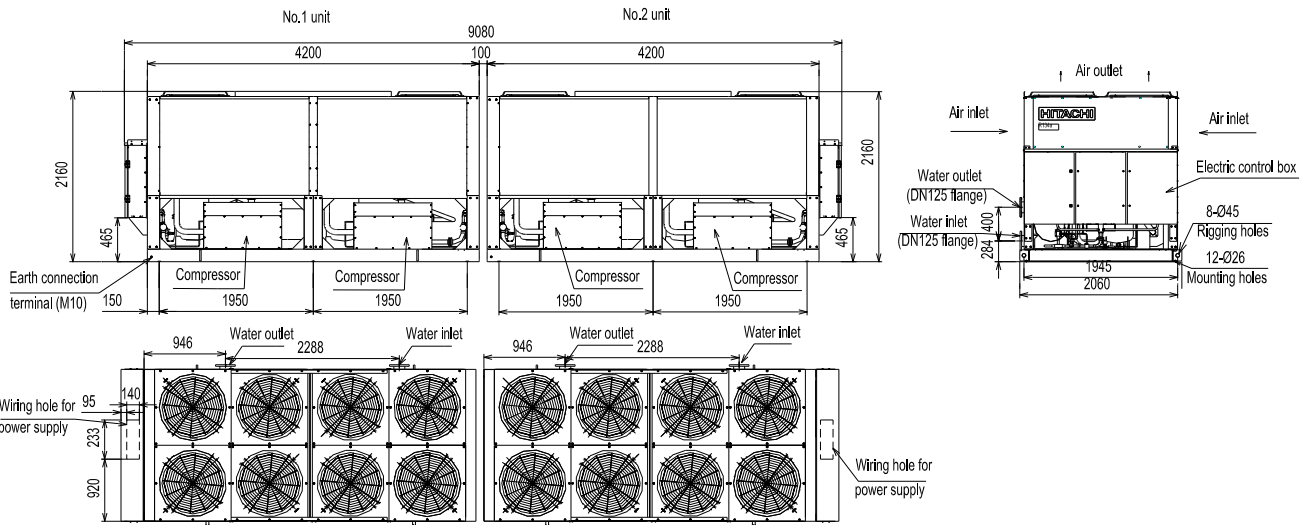

RCUF240AZPY1

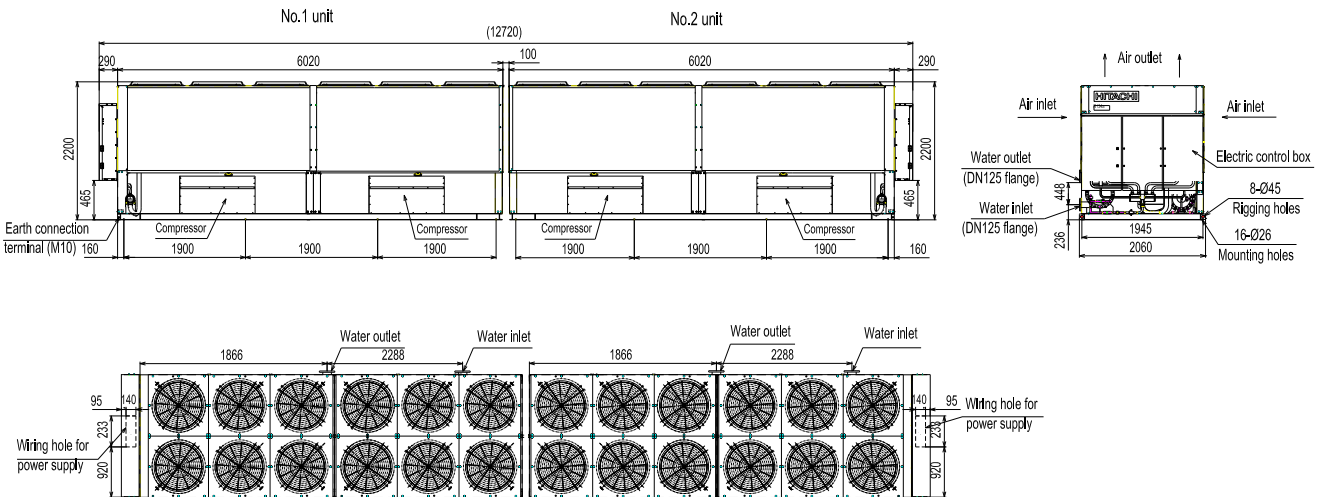

RCUF270AZY1

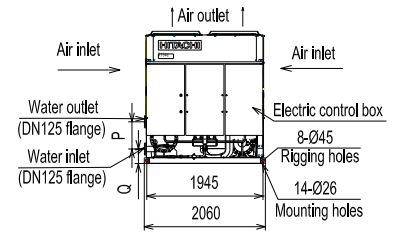
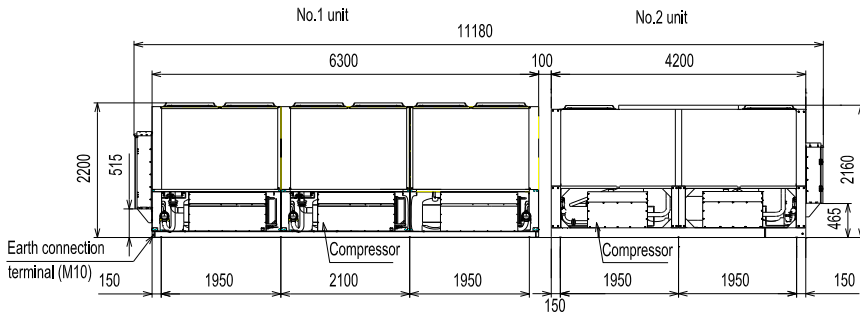

Unit	P	Q
NO.1	448	236
NO.2	400	284

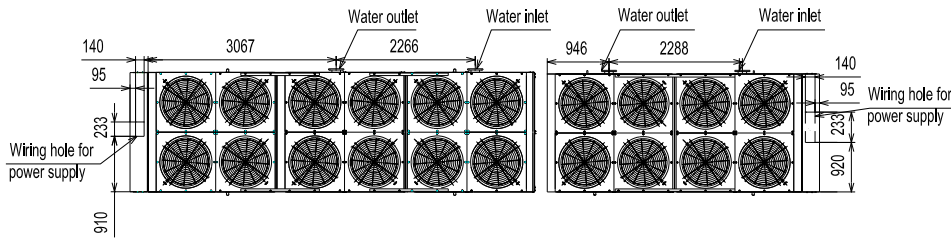

RCUF300AZY1 / RCUF330AZY1 / RCUF360AZY1 / RCUF270AZPY1 / RCUF300AZPY1

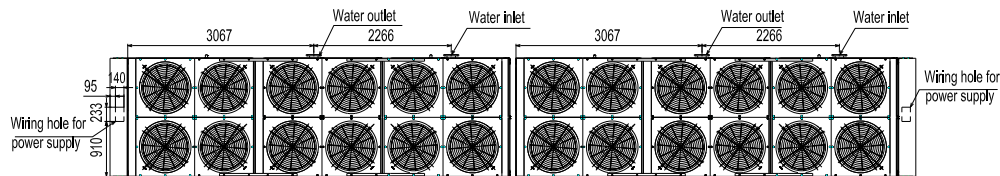
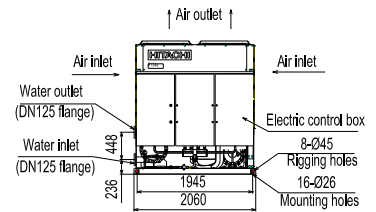
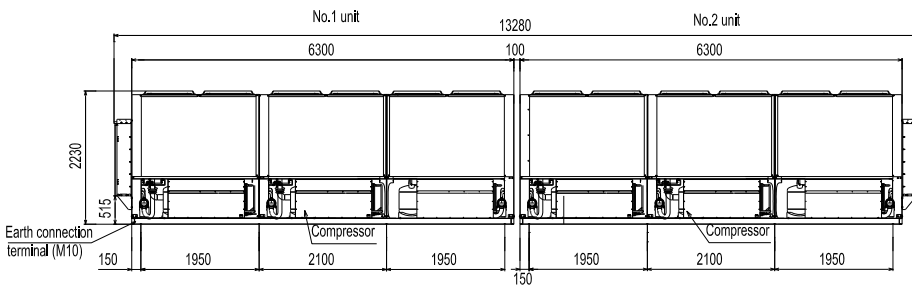

RCUF320AZPY1

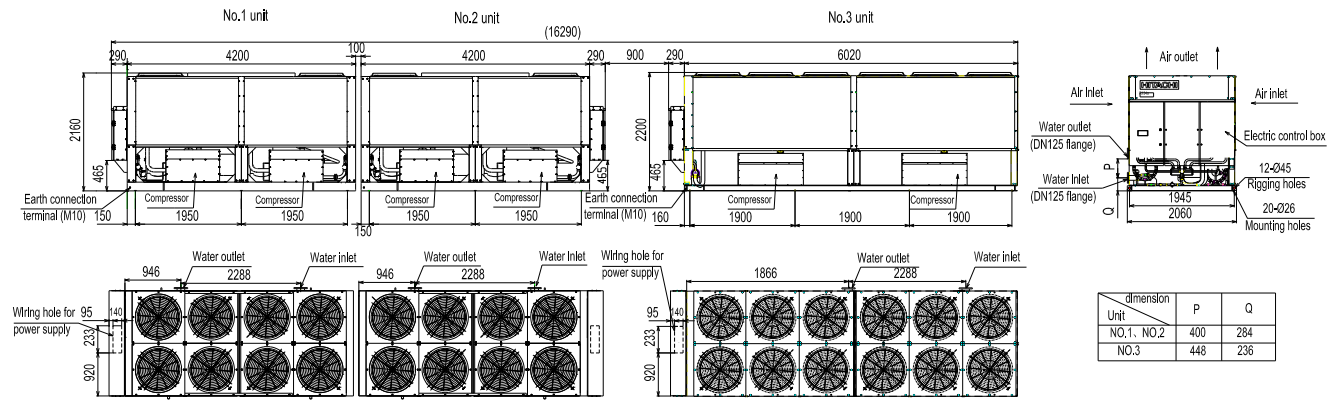

RCUF360AZPY1

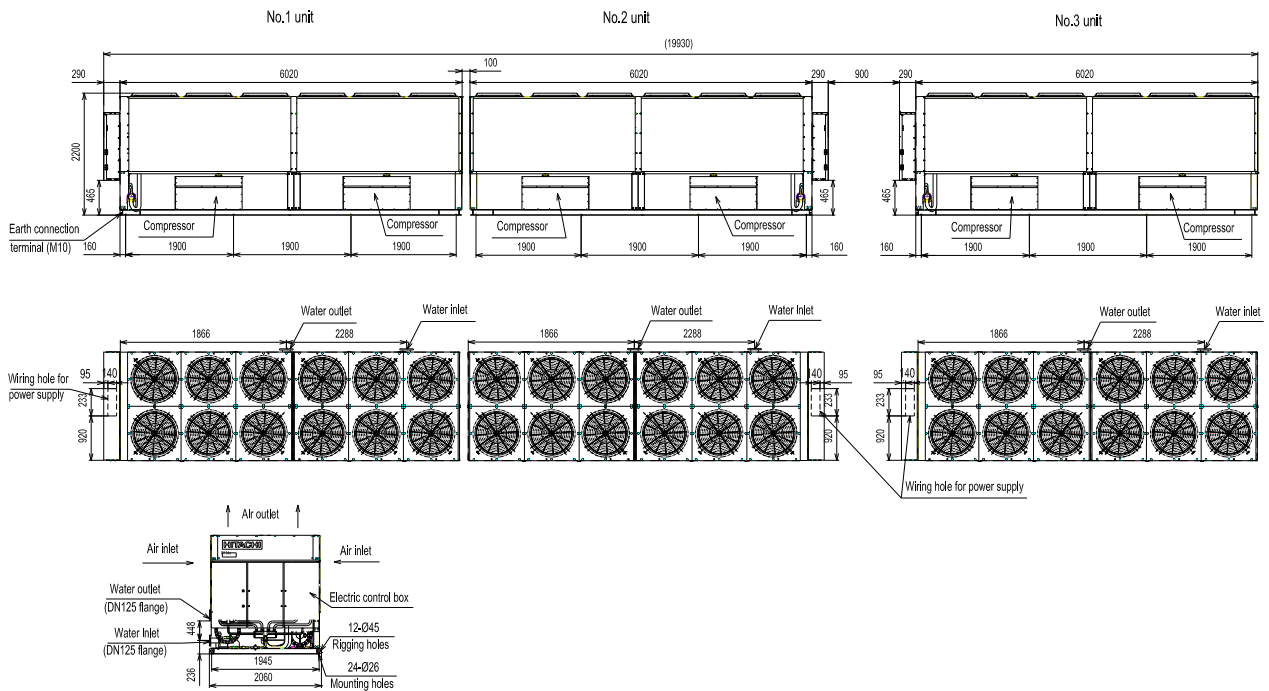

RCUF400AZY1 / RCUF420AZY1

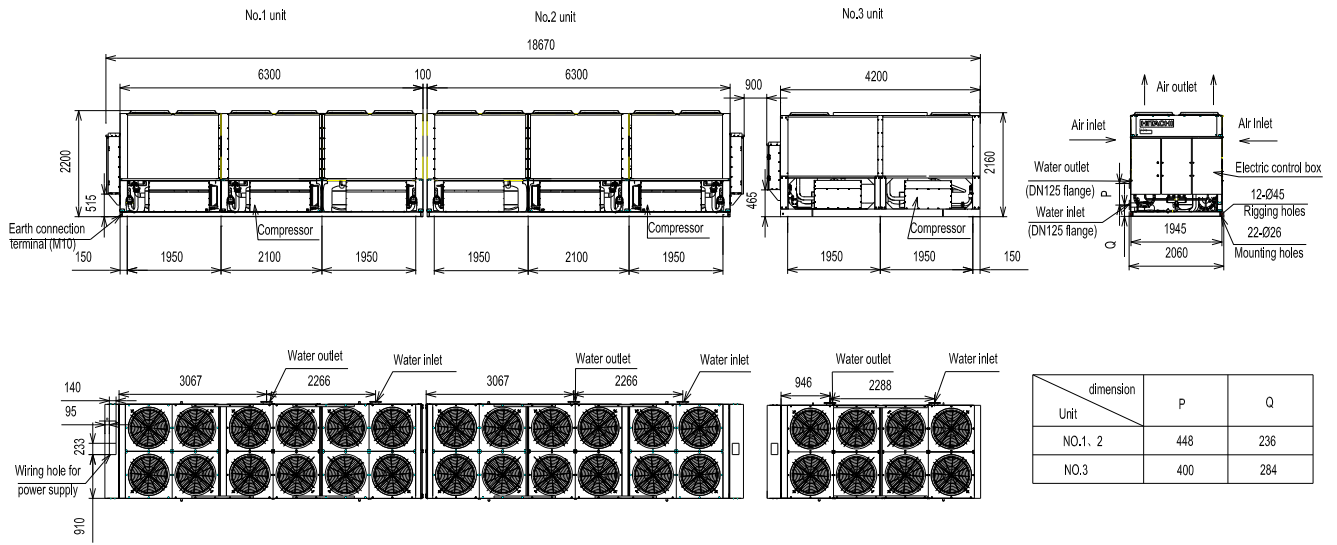

RCUF450AZY1 / RCUF405AZPY1 / RCUF420AZPY1 / RCUF450AZPY1

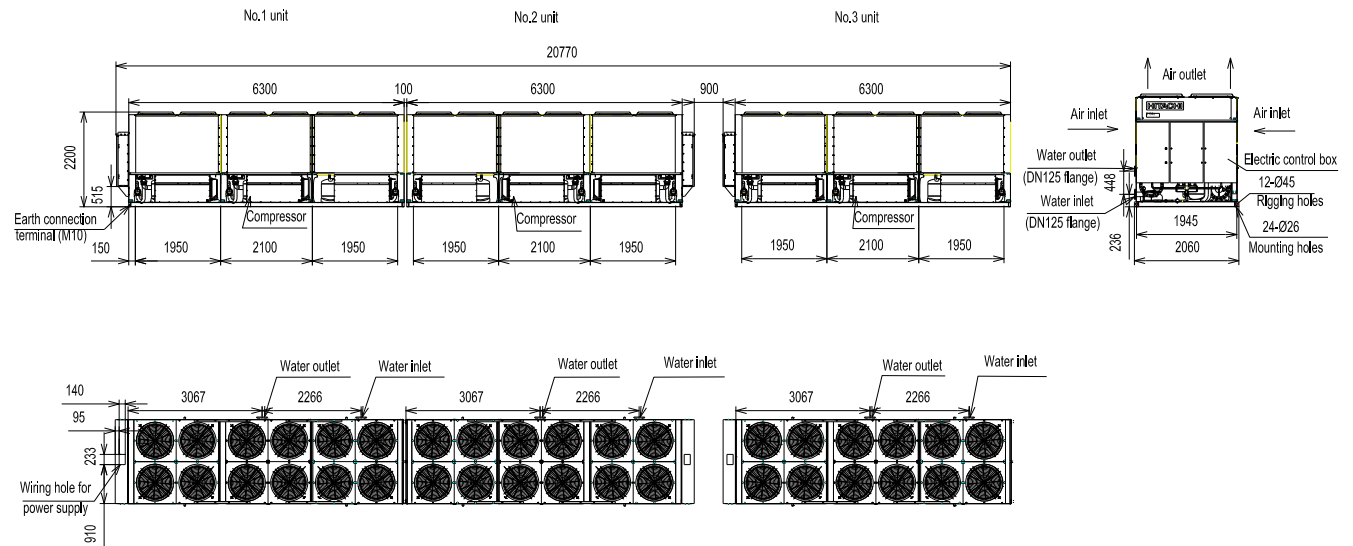

4. Operation Space

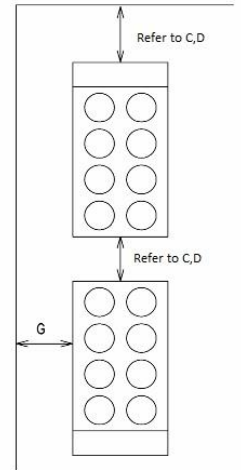
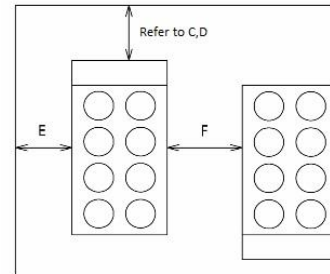
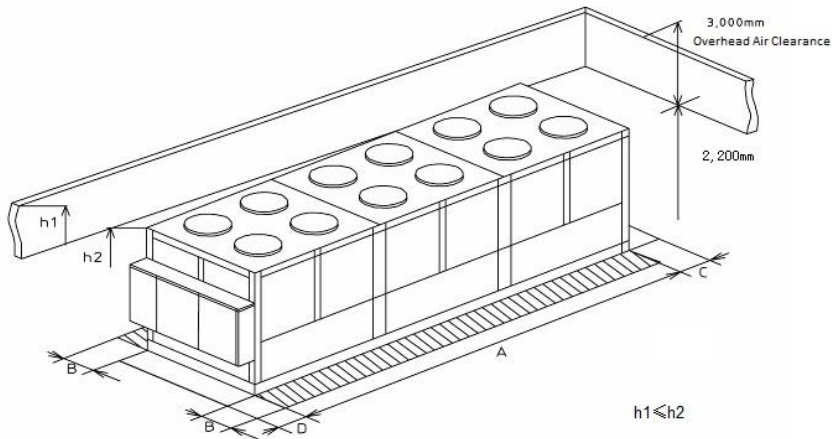

Model	Maintain Space (mm)				Air Inlet Space (mm)		
	A	B	C	D	E	F	G
RCUF45AZY1	2,390	1,200	100	900	1,200	2,000	1,200
RCUF50AZY1	2,390	1,200	100	900	1,200	2,000	1,200
RCUF60AZY1	2,390	1,200	100	900	1,200	2,000	1,200
RCUF90AZY1	4,490	1,200	100	900	1,200	2,000	1,200
RCUF100AZY1	4,490	1,200	100	900	1,200	2,000	1,200
RCUF120AZY1	4,490	1,200	100	900	1,200	2,000	1,200
RCUF150AZY1	6,590	1,200	100	900	1,200	2,000	1,200
RCUF180AZY1	6,590	1,200	100	900	1,200	2,000	1,200
RCUF200AZY1	9,080(Minimum)	1,200	100	900	1,200	2,000	1,200
RCUF220AZY1	9,080(Minimum)	1,200	100	900	1,200	2,000	1,200
RCUF240AZY1	9,080(Minimum)	1,200	900	900	1,200	2,000	1,200
RCUF270AZY1	11,180(Minimum)	1,200	900	900	1,200	2,000	1,200
RCUF300AZY1	13,280(Minimum)	1,200	900	900	1,200	2,000	1,200
RCUF330AZY1	13,280(Minimum)	1,200	900	900	1,200	2,000	1,200
RCUF360AZY1	13,280(Minimum)	1,200	900	900	1,200	2,000	1,200
RCUF400AZY1	18,670(Minimum)	1,200	100	900	1,200	2,000	1,200
RCUF420AZY1	18,670(Minimum)	1,200	100	900	1,200	2,000	1,200
RCUF450AZY1	20,770(Minimum)	1,200	100	900	1,200	2,000	1,200
RCUF45AZPY1	2,390	1,200	100	900	1,200	2,000	1,200
RCUF50AZPY1	2,390	1,200	100	900	1,200	2,000	1,200
RCUF60AZPY1	3,300	1,200	100	900	1,200	2,000	1,200
RCUF90AZPY1	4,490	1,200	100	900	1,200	2,000	1,200
RCUF100AZPY1	4,490	1,200	100	900	1,200	2,000	1,200
RCUF120AZPY1	6,310	1,200	100	900	1,200	2,000	1,200
RCUF135AZPY1	6,590	1,200	100	900	1,200	2,000	1,200
RCUF150AZPY1	6,590	1,200	100	900	1,200	2,000	1,200
RCUF180AZPY1	9,080(Minimum)	1,200	100	900	1,200	2,000	1,200
RCUF200AZPY1	9,080(Minimum)	1,200	100	900	1,200	2,000	1,200
RCUF240AZPY1	12,720(Minimum)	1,200	900	900	1,200	2,000	1,200
RCUF270AZPY1	13,280(Minimum)	1,200	900	900	1,200	2,000	1,200
RCUF300AZPY1	13,280(Minimum)	1,200	900	900	1,200	2,000	1,200
RCUF320AZPY1	16,290(Minimum)	1,200	100	900	1,200	2,000	1,200
RCUF360AZPY1	19,930(Minimum)	1,200	100	900	1,200	2,000	1,200
RCUF405AZPY1	20,770(Minimum)	1,200	100	900	1,200	2,000	1,200
RCUF420AZPY1	20,770(Minimum)	1,200	100	900	1,200	2,000	1,200
RCUF450AZPY1	20,770(Minimum)	1,200	100	900	1,200	2,000	1,200

Maximum foundation gradient

The unit shall be vertically installed in the maximum slant range as shown in Figure 1 below.

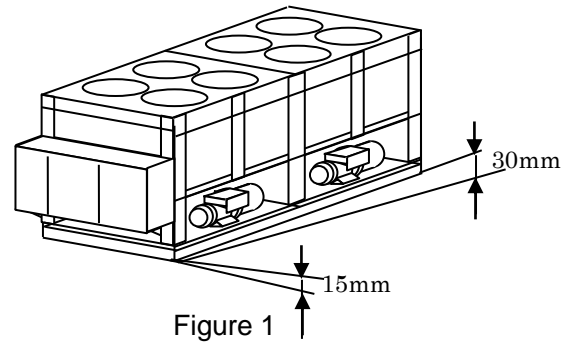

Lifting notes

1. Use lifting metal rope and stay bar supplied by the manufacturer, to keep the unit surface being scratched by the rope. The strength borne by the lifting rope shall be three times larger than the unit weight.
2. Check and ensure whether the lifting hook tightly fastens the unit. The lifting angle shall be larger than 60° . As shown in figure 2.
3. When lifting, please don't stand under the unit.
4. Add cloth between ropes and units to prevent damage of units.

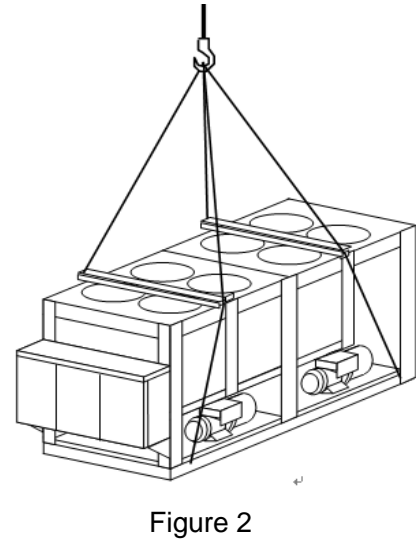

Rolling transport

When the unit rolling, place 7 same size roll bars under the chassis. Each roll bar must support two outer frames of the unit and be fit for balance of the unit.

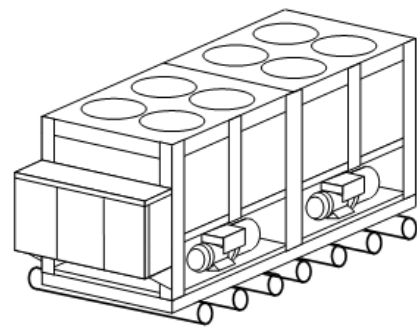

The unit's slant angle when transporting

When transporting, the unit's slant angle shall be not larger than 15° . In case of the slant angle exceeding 15° , the unit may topple over.

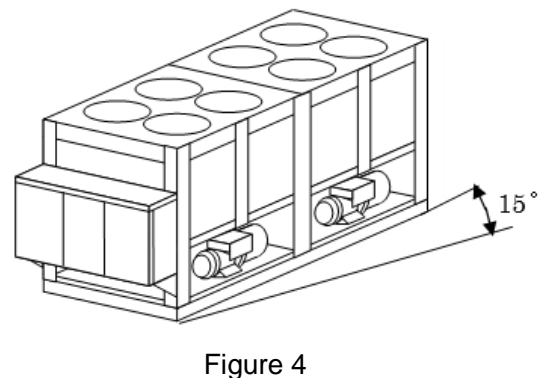

5. Center of Gravity

Model	Center of Gravity		Operation Weight(kg)	Model	Center of Gravity		Operation Weight(kg)
	X	Y			X	Y	
RCUF45AZPY1	1348	991	1700	RCUF45AZY1	1341	967	1640
RCUF50AZPY1	1348	990	1800	RCUF50AZY1	1341	967	1690
RCUF60AZPY1	1729	984	2100	RCUF60AZY1	1345	960	1800
RCUF90AZPY1	2269	912	3100	RCUF90AZY1	2268	901	3050
RCUF100AZPY1	2277	915	3300	RCUF100AZY1	2272	903	3160
RCUF120AZPY1	3184	931	3950	RCUF120AZY1	2281	900	3390
RCUF135AZPY1	3320	860	4750	RCUF150AZY1	3309	855	4890
RCUF150AZPY1	3325	865	4950	RCUF180AZY1	3319	854	5130
RCUF180AZPY1-1	2269	912	3100	RCUF200AZY1-1	2272	903	3160
RCUF180AZPY1-2	2269	912	3100	RCUF200AZY1-2	2272	903	3160
RCUF200AZPY1-1	2277	915	3300	RCUF220AZY1-1	2281	900	3390
RCUF200AZPY1-2	2277	915	3300	RCUF220AZY1-2	2272	903	3160
RCUF240AZPY1-1	3184	931	3950	RCUF240AZY1-1	2281	900	3390
RCUF240AZPY1-2	3184	931	3950	RCUF240AZY1-2	2281	900	3390
RCUF270AZPY1-1	3320	860	4750	RCUF270AZY1-1	3309	855	4890
RCUF270AZPY1-2	3320	860	4750	RCUF270AZY1-2	2281	900	3390
RCUF300AZPY1-1	3325	865	4950	RCUF300AZY1-1	3309	855	4890
RCUF300AZPY1-2	3325	865	4950	RCUF300AZY1-2	3309	855	4890
RCUF320AZPY1-1	3184	931	3950	RCUF330AZY1-1	3319	854	5130
RCUF320AZPY1-2	2277	915	3300	RCUF330AZY1-2	3309	855	4890
RCUF320AZPY1-3	2277	915	3300	RCUF360AZY1-1	3319	854	5130
RCUF360AZPY1-1	3184	931	3950	RCUF360AZY1-2	3319	854	5130
RCUF360AZPY1-2	3184	931	3950	RCUF400AZY1-1	3309	855	4890
RCUF360AZPY1-3	3184	931	3950	RCUF400AZY1-2	3309	855	4890
RCUF405AZPY1-1	3320	860	4750	RCUF400AZY1-3	2272	903	3160
RCUF405AZPY1-2	3320	860	4750	RCUF420AZY1-1	3309	855	4890
RCUF405AZPY1-3	3320	860	4750	RCUF420AZY1-2	3309	855	4890
RCUF420AZPY1-1	3320	860	4750	RCUF420AZY1-3	2281	900	3390
RCUF420AZPY1-2	3320	860	4750	RCUF450AZY1-1	3309	855	4890
RCUF420AZPY1-3	3325	865	4950	RCUF450AZY1-2	3309	855	4890
RCUF450AZPY1-1	3325	865	4950	RCUF450AZY1-3	3309	855	4890
RCUF450AZPY1-2	3325	865	4950				
RCUF450AZPY1-3	3325	865	4950				

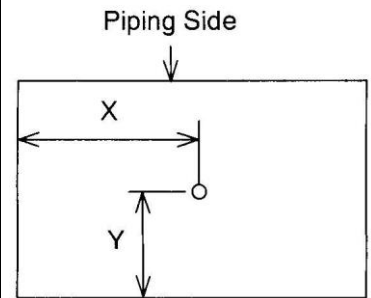

6. Weight Balance

Model	Weight Distribution (kg)			
	1	2	3	4
RCUF45AZY1	386	435	434	385
RCUF50AZY1	398	449	447	396
RCUF60AZY1	424	480	476	420
RCUF45AZPY1	394	447	456	403
RCUF50AZPY1	417	474	483	426
RCUF60AZPY1	509	534	541	516

Chilled Water Piping

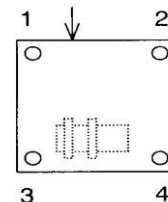

Model	Weight Distribution (kg)					
	1	2	3	4	5	6
RCUF90AZY1	524	526	529	493	490	488
RCUF100AZY1	542	545	548	512	509	506
RCUF120AZY1	581	585	590	549	545	540
RCUF200AZY1-1	542	545	548	512	509	506
RCUF200AZY1-2	542	545	548	512	509	506
RCUF220AZY1-1	581	585	590	549	545	540
RCUF220AZY1-2	542	545	548	512	509	506
RCUF240AZY1-1	581	585	590	549	545	540
RCUF240AZY1-2	581	585	590	549	545	540
RCUF270AZY1-2	581	585	590	549	545	540
RCUF400AZY1-3	542	545	548	512	509	506
RCUF420AZY1-3	581	585	590	549	545	540
RCUF90AZPY1	529	532	535	504	501	499
RCUF100AZPY1	562	566	569	538	534	531
RCUF120AZPY1	669	672	675	648	645	642
RCUF180AZPY1-1	529	532	535	504	501	499
RCUF180AZPY1-2	529	532	535	504	501	499
RCUF200AZPY1-1	562	566	569	538	534	531
RCUF200AZPY1-2	562	566	569	538	534	531
RCUF240AZPY1-1	669	672	675	648	645	642
RCUF240AZPY1-2	669	672	675	648	645	642
RCUF320AZPY1-1	562	566	569	538	534	531
RCUF320AZPY1-2	562	566	569	538	534	531
RCUF320AZPY1-3	669	672	675	648	645	642
RCUF360AZPY1-1	669	672	675	648	645	642
RCUF360AZPY1-2	669	672	675	648	645	642
RCUF360AZPY1-3	669	672	675	648	645	642

Chilled Water Piping

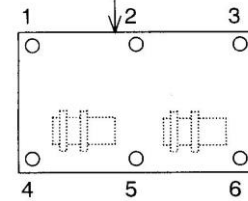

Model	Weight Distribution (kg)							
	1	2	3	4	5	6	7	8
RCUF150AZY1	646	644	651	649	576	578	572	574
RCUF180AZY1	677	673	686	682	605	610	596	601
RCUF270AZY1-1	646	644	651	649	576	578	572	574
RCUF300AZY1-1	646	644	651	649	576	578	572	574
RCUF300AZY1-2	646	644	651	649	576	578	572	574
RCUF330AZY1-1	677	673	686	682	605	610	596	601
RCUF330AZY1-2	646	644	651	649	576	578	572	574
RCUF360AZY1-1	677	673	686	682	605	610	596	601
RCUF360AZY1-2	677	673	686	682	605	610	596	601
RCUF400AZY1-1	646	644	651	649	576	578	572	574
RCUF400AZY1-2	646	644	651	649	576	578	572	574
RCUF420AZY1-1	646	644	651	649	576	578	572	574
RCUF420AZY1-2	646	644	651	649	576	578	572	574
RCUF450AZY1-1	646	644	651	649	576	578	572	574
RCUF450AZY1-2	646	644	651	649	576	578	572	574
RCUF450AZY1-3	646	644	651	649	576	578	572	574
RCUF135AZPY1	625	621	634	630	563	567	554	558
RCUF150AZPY1	650	644	661	655	588	594	577	583
RCUF270AZPY1-1	625	621	634	630	563	567	554	558
RCUF270AZPY1-2	625	621	634	630	563	567	554	558
RCUF300AZPY1-1	650	644	661	655	588	594	577	583
RCUF300AZPY1-2	650	644	661	655	588	594	577	583
RCUF405AZPY1-1	625	621	634	630	563	567	554	558
RCUF405AZPY1-2	625	621	634	630	563	567	554	558
RCUF405AZPY1-3	625	621	634	630	563	567	554	558
RCUF420AZPY1-1	650	644	661	655	588	594	577	583
RCUF420AZPY1-2	625	621	634	630	563	567	554	558
RCUF420AZPY1-3	625	621	634	630	563	567	554	558
RCUF450AZPY1-1	650	644	661	655	588	594	577	583
RCUF450AZPY1-2	650	644	661	655	588	594	577	583
RCUF450AZPY1-3	650	644	661	655	588	594	577	583

Chilled Water Piping

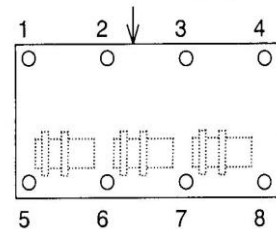

7. Recommended Concrete Curbs

RCUF45, 50, 60AZY1
RCUF45, 50AZPY1

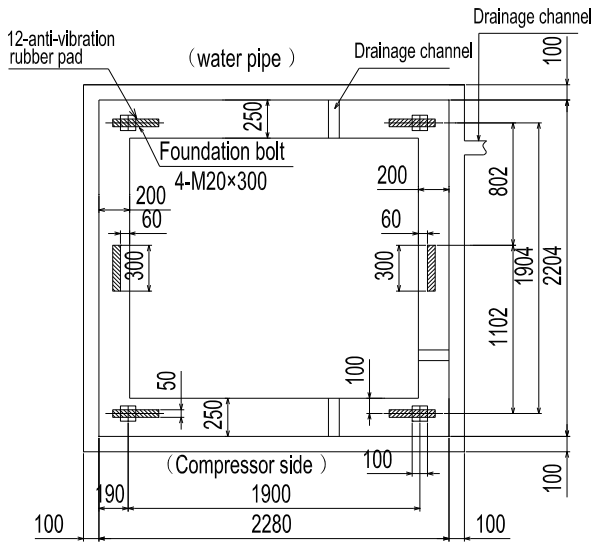

Detail drawing of foundation installation
(not to scale)

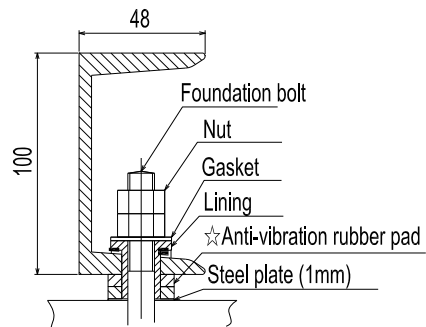

☆: Manufacturer's supplies

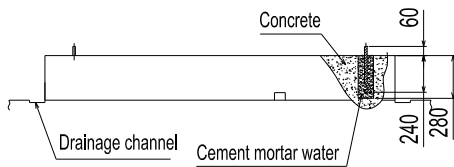

RCUF60AZPY1

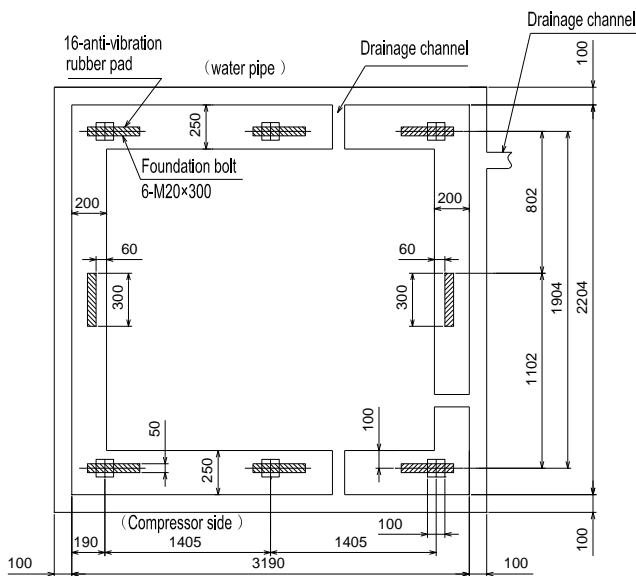

Detail drawing of foundation installation
(not to scale)

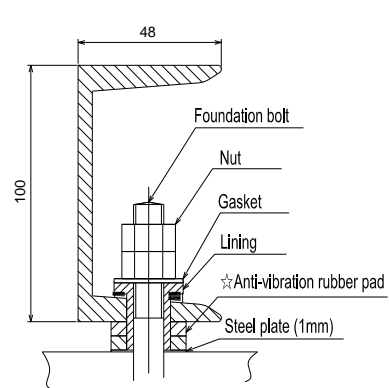

☆: Manufacturer's supplies

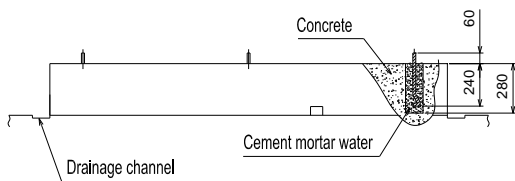

RCUF90, 100, 120AZY1
RCUF90, 100AZPY1

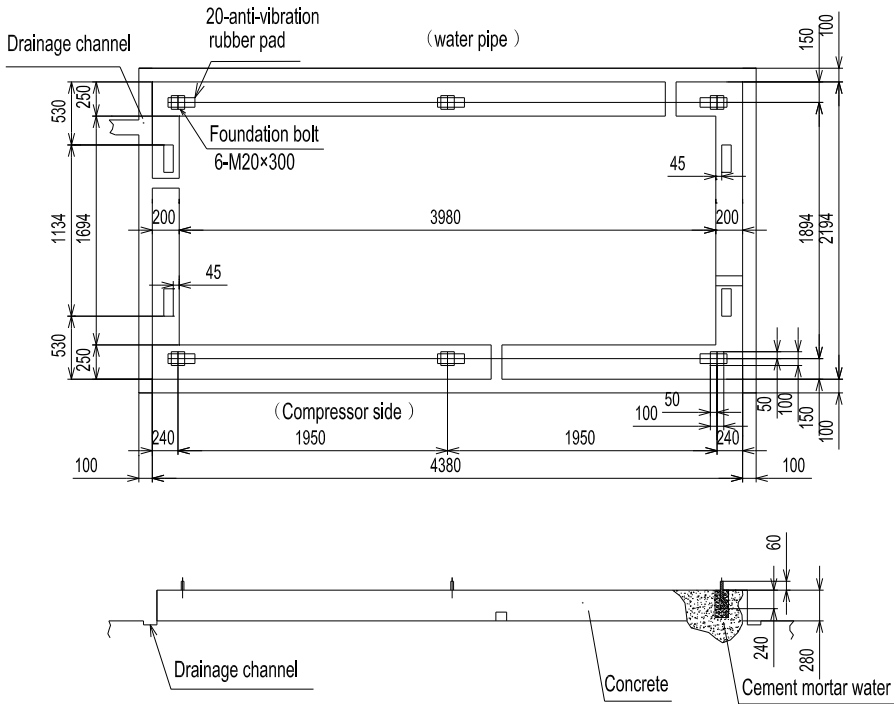

Detail drawing of foundation installation

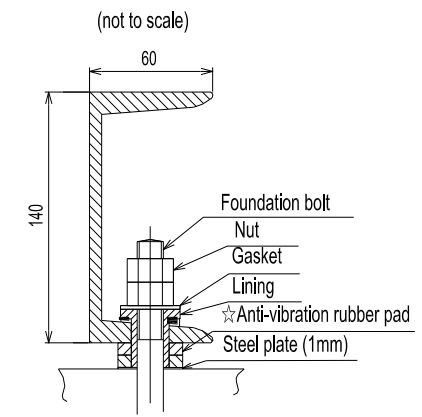

RCUF120AZPY1

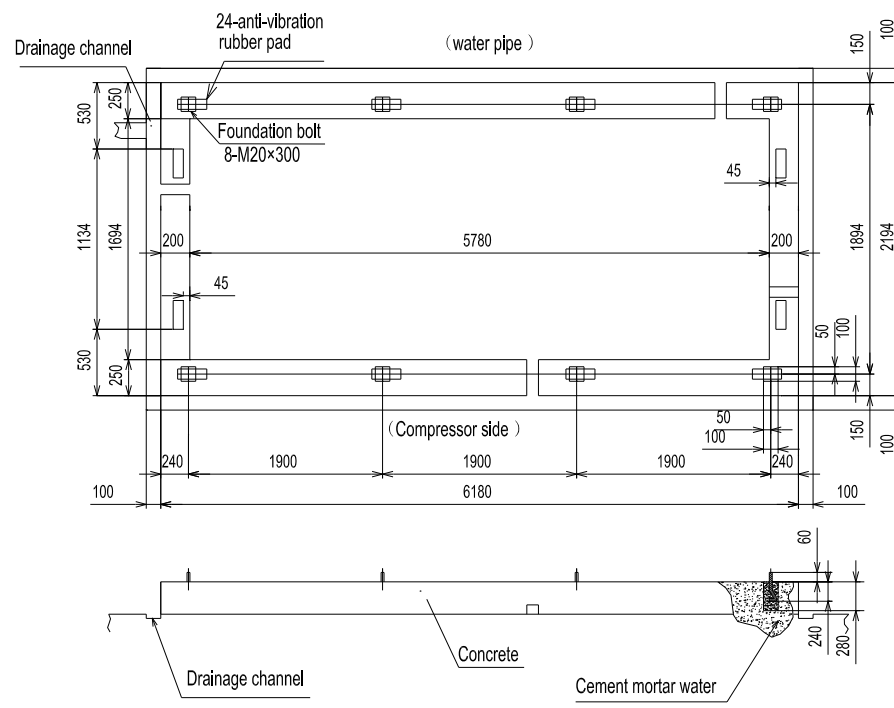

Detail drawing of foundation installation

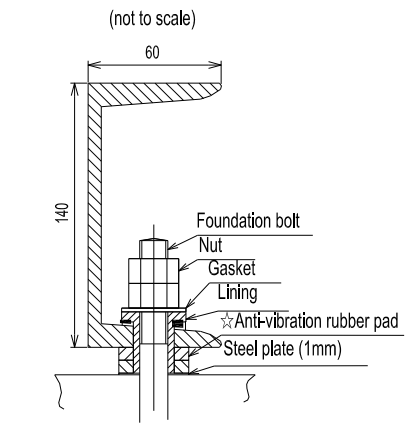

RCUF150, 180AZY1
RCUF135, 150AZPY1

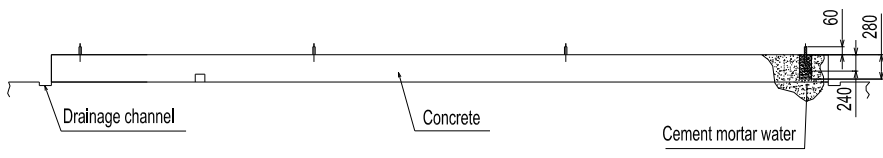
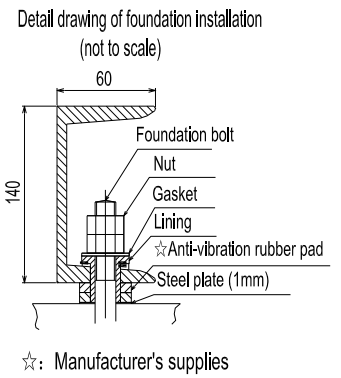
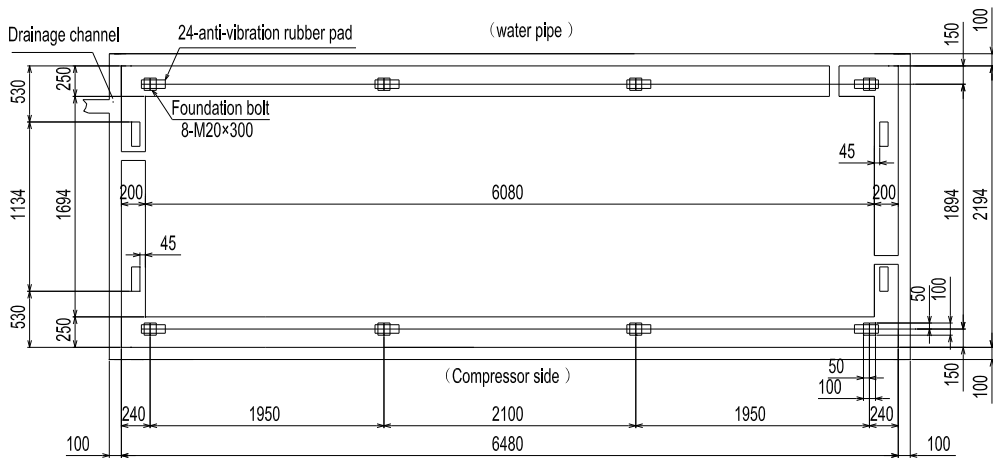

RCUF200, 220, 240AZY1
RCUF180, 200AZPY1

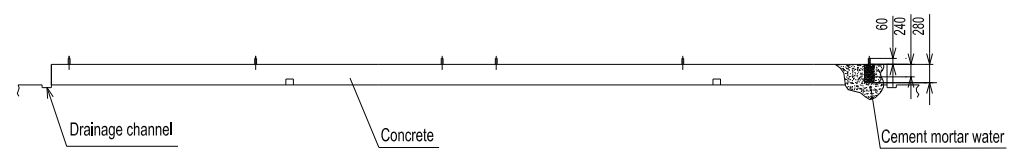
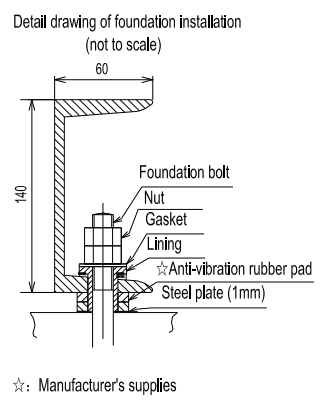
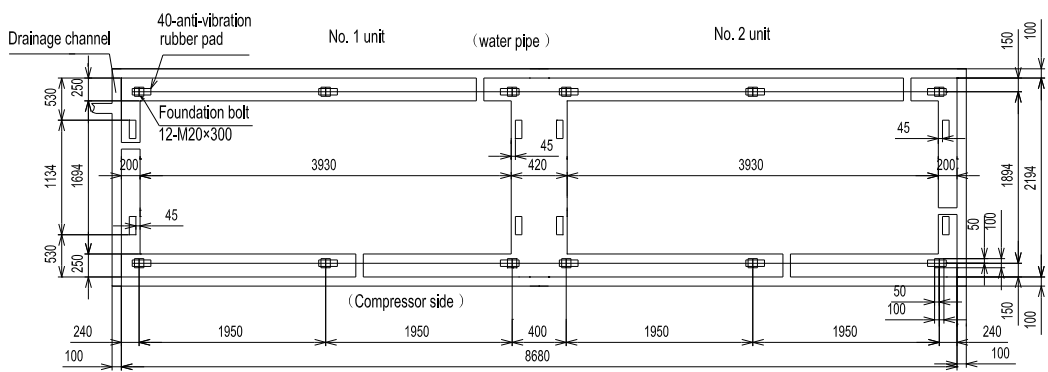

RCUF240AZPY1

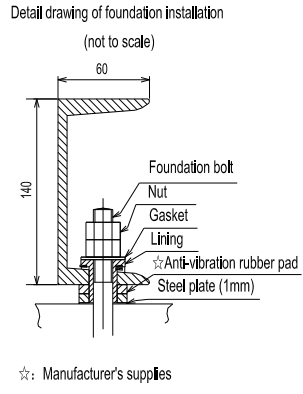
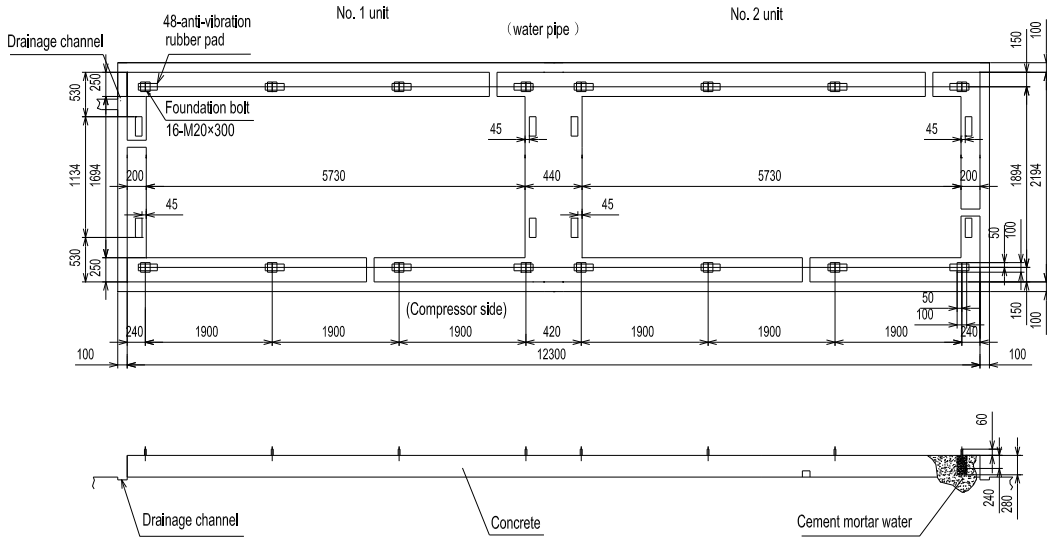

RCUF270AZY1

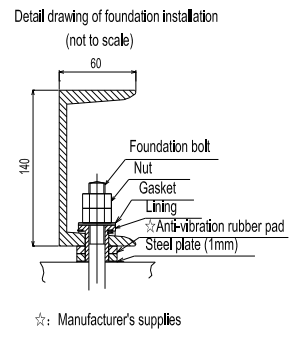
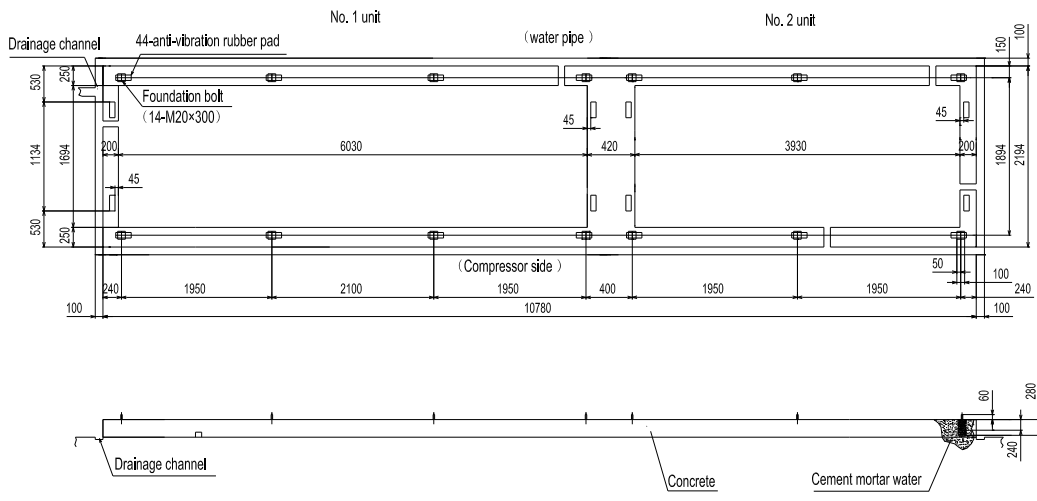

RCUF300, 330, 360AZY1 RCUF270, 300AZY1

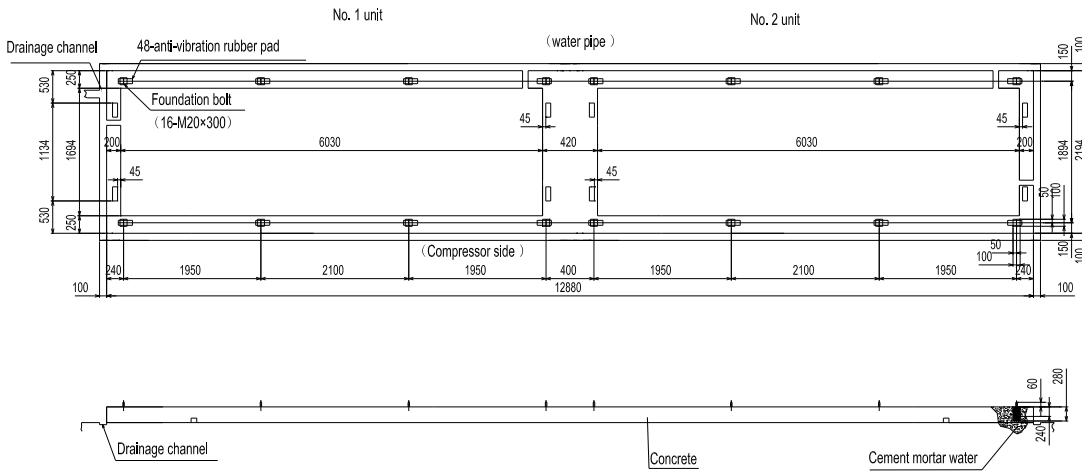

Detail drawing of foundation installation (not to scale)

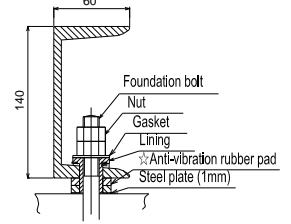

☆: Manufacturer's supplies

RCUF320AZY1

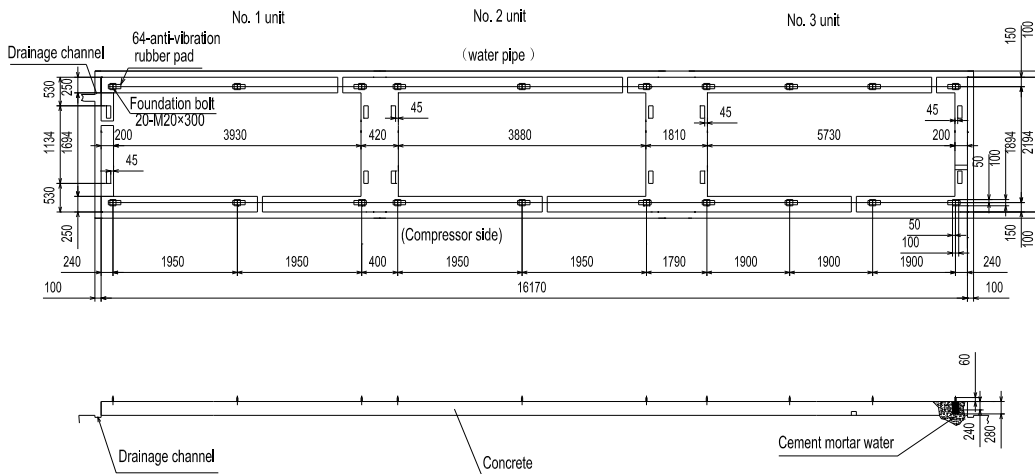

Detail drawing of foundation installation (not to scale)

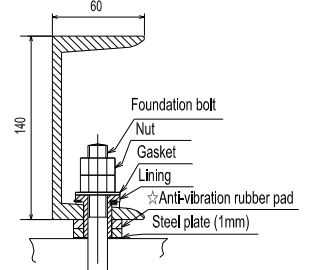

☆: Manufacturer's supplies

RCUF360AZY1

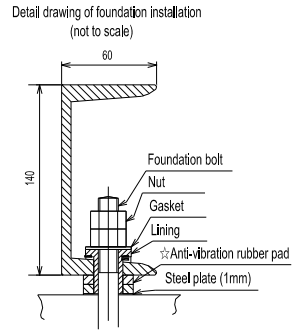
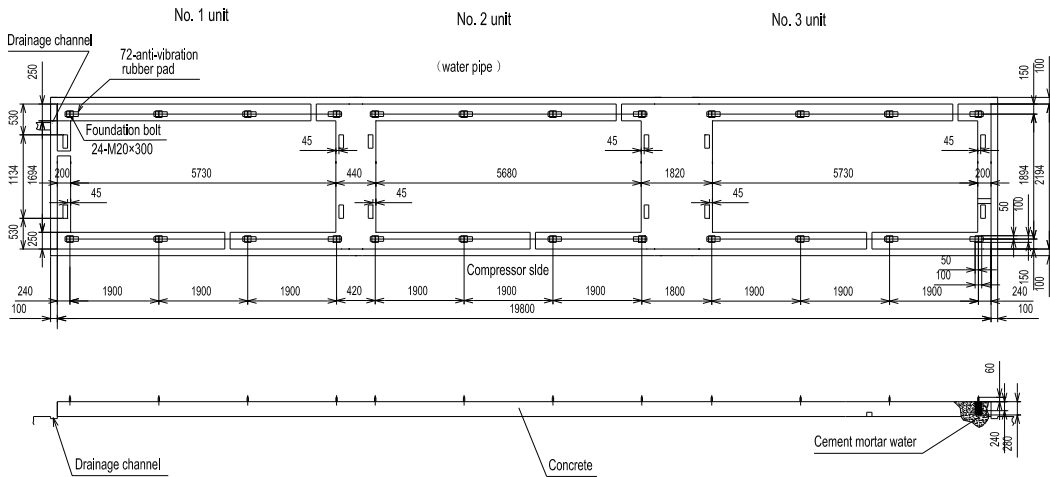

☆: Manufacturer's supplies

RCUF400, 420AZY1

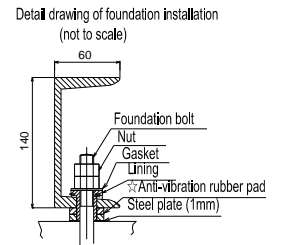
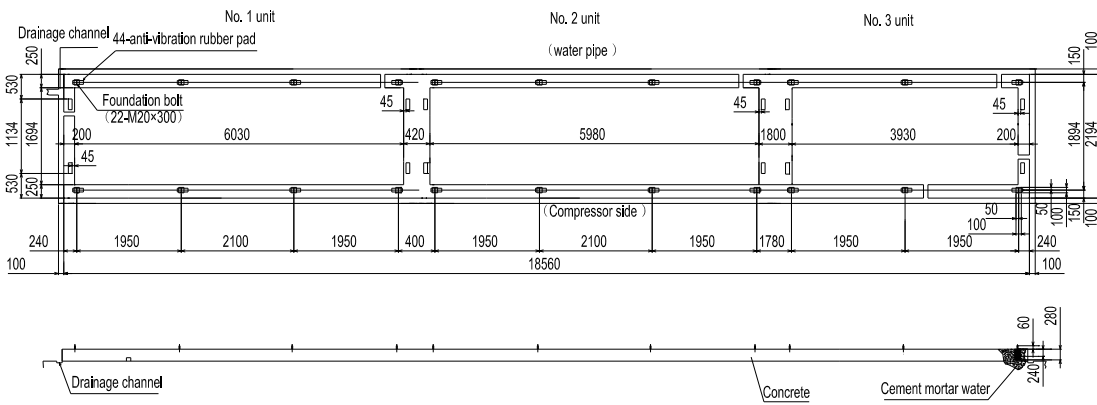

☆: Manufacturer's supplies

RCUF450AZY1 / RCUF405, 420, 450AZY1

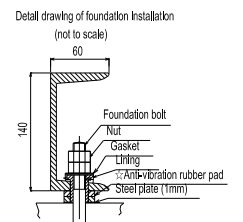
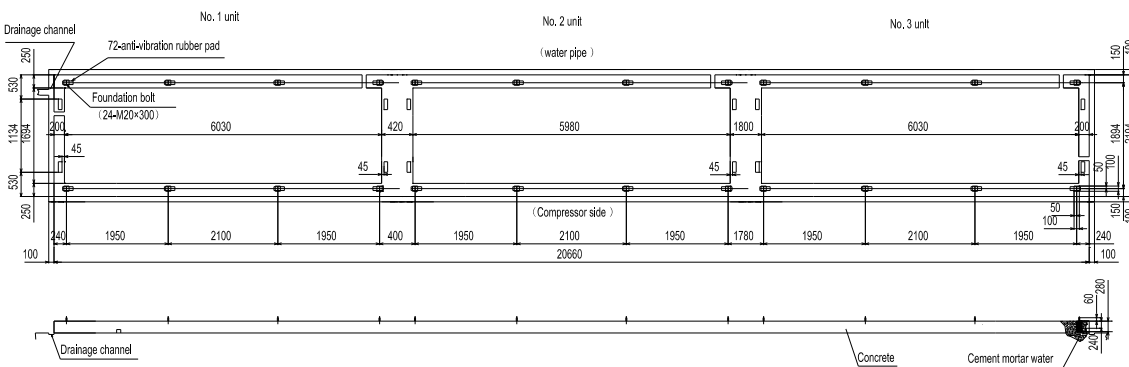

☆: Manufacturer's supplies

8. Selection Example

Determination the System Requirements:

Condenser Air Inlet Temperature:	40°C
Chilled Water Outlet Temperature	7°C
Chilled Water Inlet Temperature	12°C
Cooling Load	450kW
Power Source Frequency:	50Hz

From the cooling capacity table, model **RCUF150AZY1** can be selected with the following performance:

Cooling Capacity:	517kW
Chilled Water Flow Rate:	88.9m ³ /h
Water Cooler Pressure Drop:	45 kPa
Compressor Input Power:	182.8kW

The water flow rate in the cooling capacity table is based on the 5 °C temperature difference between the chilled water inlet and outlet temperature, if the temperature difference is not 5 °C , correct the water flow rater of the water cooler utilizing follow formulas.

$$\text{Corrected Flow Rate} = \frac{\text{Flow Rate From the Table (CFR)} \times 5^{\circ\text{C}}}{\text{Given Temperature Difference } (^{\circ}\text{C})}$$

The corrected chilled water flow rate must be confirmed to be within the working range described on pages 42.

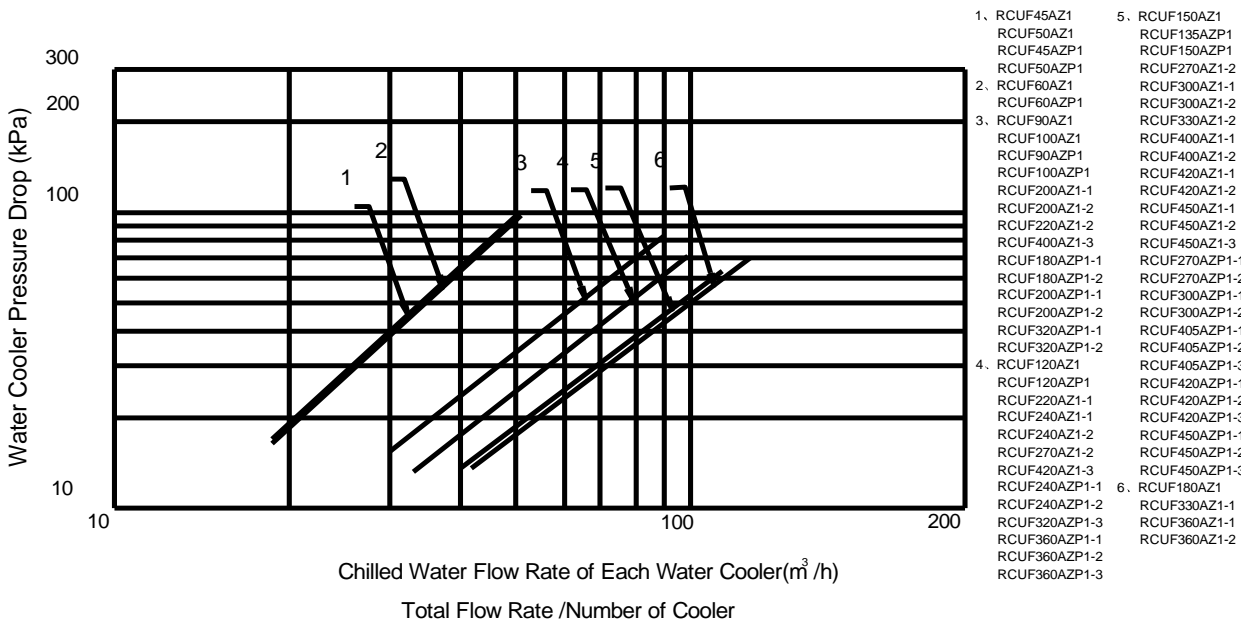

Note: The flow rate of each model is different; please refer to the chilled water flow rate on the pages 27 to 38.

Cooling Capacity and Compressor Input

When the fouling factor is different from 0.018m². °C /kW, the cooling capacity or the compressor input will be corrected utilizing follow formulas:

$$\text{Corrected Cooling Capacity} = \text{Correction Factor} \times \text{Cooling Capacity Indicated in Table}$$

and

$$\text{Corrected Compressor Input} = \text{Correction Factor} \times \text{Compressor Input indicated in Table}$$

Correction Factor for Cooling Capacity and Compressor Input Regarding Fouling Factor

	Fouling Factor m ² .°C/kW	Cooling Capacity	Compressor Input
Water	0.000	1.01	1.00
Cooler	0.018	1.00	1.00

9. Cooling Capacities

Conversion Multiplier: 1kW=860kcal/h
 =3412Btu/h
 1kPa=0.102mAq

ABT	COLT	RCUF45AZY1				RCUF50AZY1				RCUF60AZY1				RCUF90AZY1			
		CCAP	CFR	CPD	IPT	CCAP	CFR	CPD	IPT	CCAP	CFR	CPD	IPT	CCAP	CFR	CPD	IPT
25	5	153	26.3	29	33.3	169	29.1	37	36.8	208	35.8	52	45.3	306	52.6	38	66.5
	6	159	27.4	32	34.4	177	30.4	41	38.1	217	37.3	56	46.8	319	54.9	41	68.7
	7	166	28.6	36	35.5	184	31.6	45	39.3	226	38.9	60	48.3	332	57.1	44	70.9
	8	173	29.7	39	36.6	191	32.9	49	40.5	235	40.4	64	49.8	345	59.4	48	73.1
	9	179	30.8	42	37.7	199	34.2	54	41.8	244	42.0	68	51.3	359	61.7	51	75.3
	10	186	32.0	46	38.8	206	35.4	58	43.0	253	43.5	72	52.8	372	63.9	55	77.6
	11	192	33.1	50	39.9	213	36.7	63	44.2	262	45.0	76	54.3	385	66.2	59	79.8
	12	199	34.2	54	41.0	220	37.9	68	45.4	271	46.6	81	55.9	398	68.5	63	82.0
	13	206	35.4	58	42.2	228	39.2	73	46.7	280	48.1	85	57.4	411	70.7	67	84.2
	14	212	36.5	62	43.3	235	40.4	79	47.9	289	49.7	90	58.9	424	73.0	71	86.4
15	219	37.6	67	44.4	242	41.7	85	49.1	298	51.2	94	60.4	438	75.3	75	88.6	
30	5	150	25.8	28	40.2	166	28.6	36	44.5	204	35.1	51	54.7	300	51.6	37	80.4
	6	156	26.8	31	41.1	173	29.7	39	45.5	212	36.5	54	55.9	312	53.7	39	82.1
	7	162	27.9	34	42.0	179	30.9	43	46.5	221	37.9	57	57.2	324	55.7	42	83.9
	8	168	28.9	37	42.9	186	32.0	46	47.5	229	39.3	61	58.4	336	57.8	45	85.7
	9	174	29.9	40	43.8	193	33.2	50	48.5	237	40.8	65	59.6	348	59.9	49	87.5
	10	180	31.0	43	44.7	200	34.3	54	49.5	245	42.2	68	60.8	360	62.0	52	89.2
	11	186	32.0	46	45.6	206	35.5	58	50.4	253	43.6	72	62.0	372	64.1	55	91.0
	12	192	33.1	50	46.4	213	36.6	63	51.4	262	45.0	76	63.2	384	66.1	59	92.8
	13	198	34.1	53	47.3	220	37.8	67	52.4	270	46.4	80	64.4	397	68.2	62	94.6
	14	204	35.1	57	48.2	226	38.9	72	53.4	278	47.8	84	65.6	409	70.3	66	96.3
15	210	36.2	61	49.1	233	40.1	77	54.4	286	49.2	88	66.8	421	72.4	70	98.1	
35	5	147	25.3	27	47.2	163	28.0	34	52.2	200	34.4	49	64.2	294	50.6	35	94.2
	6	153	26.2	29	47.8	169	29.1	37	53.0	208	35.7	52	65.1	305	52.5	38	95.6
	7	158	27.2	34	48.5	175	30.1	40	53.7	215	37.0	55	66.0	316	54.4	40	96.9
	8	163	28.1	37	49.2	181	31.1	43	54.4	222	38.3	58	66.9	327	56.2	43	98.2
	9	169	29.1	39	49.8	187	32.2	47	55.2	230	39.5	62	67.8	338	58.1	46	99.6
	10	174	30.0	42	50.5	193	33.2	50	55.9	237	40.8	65	68.7	349	60.0	49	100.9
	11	180	31.0	46	51.2	199	34.3	54	56.7	245	42.1	68	69.6	360	61.9	52	102.2
	12	185	31.9	49	51.8	205	35.3	58	57.4	252	43.4	72	70.6	371	63.8	55	103.6
	13	191	32.8	52	52.5	211	36.4	62	58.1	260	44.7	75	71.5	382	65.7	58	104.9
	14	196	33.8	56	53.2	218	37.4	66	58.9	267	46.0	79	72.4	393	67.6	61	106.3
15	202	34.7	59	53.8	224	38.5	70	59.6	275	47.3	83	73.3	404	69.5	65	107.6	
40	5	144	24.8	26	54.1	160	27.4	32	59.9	196	33.7	47	73.6	288	49.6	34	108.1
	6	149	25.6	28	54.6	165	28.4	35	60.4	203	34.9	50	74.2	298	51.3	36	109.0
	7	154	26.5	30	55.0	171	29.3	38	60.9	210	36.0	53	74.9	308	53.0	38	109.9
	8	159	27.3	32	55.5	176	30.3	41	61.4	216	37.2	56	75.5	318	54.7	41	110.8
	9	164	28.2	34	55.9	181	31.2	44	61.9	223	38.3	58	76.1	328	56.4	43	111.7
	10	169	29.0	37	56.3	187	32.2	47	62.4	230	39.5	61	76.7	338	58.1	46	112.6
	11	174	29.9	39	56.8	192	33.1	50	62.9	236	40.7	64	77.3	347	59.8	48	113.5
	12	179	30.7	42	57.2	198	34.0	53	63.4	243	41.8	67	77.9	357	61.5	51	114.4
	13	184	31.6	45	57.7	203	35.0	57	63.9	250	43.0	71	78.5	367	63.2	54	115.3
	14	189	32.4	48	58.1	209	35.9	60	64.4	257	44.1	74	79.1	377	64.9	57	116.2
15	193	33.3	50	58.6	214	36.9	64	64.9	263	45.3	77	79.7	387	66.6	60	117.1	
43	5	142	24.5	25	58.3	158	27.1	32	64.5	194	33.3	46	79.3	285	49.0	33	116.4
	6	147	25.3	27	58.6	163	28.0	34	64.9	200	34.4	49	79.7	294	50.5	35	117.1
	7	152	26.1	29	58.9	168	28.9	36	65.2	206	35.5	51	80.2	303	52.1	37	117.7
	8	156	26.9	31	59.2	173	29.7	39	65.6	212	36.5	54	80.6	312	53.7	39	118.3
	9	161	27.6	33	59.5	178	30.6	42	65.9	219	37.6	57	81.0	321	55.3	42	119.0
	10	165	28.4	35	59.9	183	31.5	45	66.3	225	38.7	59	81.5	331	56.9	44	119.6
	11	170	29.2	38	60.2	188	32.4	47	66.6	231	39.8	62	81.9	340	58.5	46	120.2
	12	175	30.0	40	60.5	193	33.3	50	67.0	238	40.9	65	82.3	349	60.1	49	120.8
	13	179	30.8	42	60.8	198	34.1	54	67.3	244	41.9	68	82.7	358	61.6	51	121.5
	14	184	31.6	45	61.1	204	35.0	57	67.7	250	43.0	71	83.2	368	63.2	54	122.1
15	188	32.4	48	61.4	209	35.9	60	68.0	256	44.1	74	83.6	377	64.8	57	122.7	

ABT: Condensate Air Inlet Temperature (°C)
 CCAP: Cooling Capacity (kW)
 CPD: Water Cooler Pressure Drop (kPa)

CLOT: Chilled Water Outlet Temperature (°C)
 CFR: Chilled Water Flow Rate at 5 °C Difference Between Inlet and Outlet Temperature(m³/h)
 IPT: Input Power for Unit (kW)

Conversion Multiplier: 1kW=860kcal/h
 =3412Btu/h
 1kPa=0.102mAq

ABT	COT	RCUF100AZY1				RCUF120AZY1				RCUF150AZY1				RCUF180AZY1				
		CCAP	CFR	CPD	IPT	CCAP	CFR	CPD	IPT	CCAP	CFR	CPD	IPT	CCAP	CFR	CPD	IPT	
25	5	340	58.4	44	73.9	426	73.2	45	92.6	513	88.2	44	111.6	624	107.4	57	135.8	
	6	354	60.9	48	76.4	444	76.4	48	95.7	535	92.0	48	115.3	651	112.0	61	140.3	
	7	369	63.5	52	78.8	463	79.6	51	98.8	557	95.8	51	119.0	678	116.6	65	144.8	
	8	384	66.0	56	81.3	481	82.7	55	101.9	579	99.6	55	122.7	705	121.2	69	149.4	
	9	398	68.5	60	83.7	499	85.9	58	105.0	601	103.4	58	126.4	732	125.9	74	153.9	
	10	413	71.0	64	86.2	518	89.0	61	108.1	623	107.2	62	130.2	759	130.5	78	158.4	
	11	428	73.5	69	88.7	536	92.2	65	111.2	646	111.0	66	133.9	786	135.1	83	162.9	
	12	442	76.1	73	91.1	554	95.3	69	114.2	668	114.8	70	137.6	813	139.8	87	167.5	
	13	457	78.6	78	93.6	573	98.5	72	117.3	690	118.6	75	141.3	839	144.4	92	172.0	
	14	471	81.1	83	96.1	591	101.7	76	120.4	712	122.4	79	145.0	866	149.0	97	176.5	
	15	486	83.6	88	98.5	609	104.8	80	123.5	734	126.3	83	148.8	893	153.6	101	181.0	
	30	5	333	57.3	43	89.3	418	71.8	43	111.9	503	86.5	43	134.8	612	105.3	55	164.1
		6	347	59.6	46	91.3	434	74.7	46	114.4	523	90.0	46	137.8	637	109.5	59	167.7
		7	360	61.9	49	93.3	451	77.6	49	116.9	544	93.5	49	140.8	662	113.8	63	171.4
		8	373	64.2	53	95.2	468	80.5	52	119.4	564	97.0	52	143.8	686	118.0	67	175.0
9		387	66.5	57	97.2	485	83.4	55	121.8	584	100.5	56	146.8	711	122.3	70	178.6	
10		400	68.8	61	99.2	502	86.3	58	124.3	604	103.9	59	149.7	735	126.5	74	182.2	
11		414	71.1	65	101.2	519	89.2	62	126.8	625	107.4	63	152.7	760	130.7	78	185.9	
12		427	73.5	69	103.1	535	92.1	65	129.3	645	110.9	66	155.7	785	135.0	82	189.5	
13		440	75.8	73	105.1	552	95.0	68	131.7	665	114.4	70	158.7	809	139.2	87	193.1	
14		454	78.1	77	107.1	569	97.9	72	134.2	685	117.9	74	161.7	834	143.5	91	196.8	
15		467	80.4	82	109.1	586	100.8	75	136.7	706	121.4	78	164.6	859	147.7	95	200.4	
35		5	327	56.2	41	104.7	409	70.4	42	131.3	493	84.8	41	158.1	600	103.2	54	192.4
		6	339	58.3	44	106.2	425	73.1	45	133.1	512	88.0	44	160.4	623	107.1	57	195.2
		7	351	60.4	46	107.7	440	75.7	46	135.0	530	91.2	46	162.6	645	110.9	60	197.9
		8	363	62.5	50	109.2	455	78.3	50	136.9	548	94.3	50	164.8	667	114.8	64	200.6
	9	375	64.6	54	110.7	471	80.9	53	138.7	567	97.5	53	167.1	690	118.6	67	203.4	
	10	388	66.7	57	112.2	486	83.6	55	140.6	585	100.7	56	169.3	712	122.5	71	206.1	
	11	400	68.8	61	113.6	501	86.2	58	142.4	604	103.8	59	171.6	735	126.4	74	208.8	
	12	412	70.9	64	115.1	516	88.8	61	144.3	622	107.0	62	173.8	757	130.2	78	211.5	
	13	424	73.0	68	116.6	532	91.5	64	146.2	640	110.2	65	176.1	779	134.1	82	214.3	
	14	436	75.1	72	118.1	547	94.1	67	148.0	659	113.3	69	178.3	802	137.9	85	217.0	
	15	449	77.2	75	119.6	562	96.7	70	149.9	677	116.5	72	180.5	824	141.8	89	219.7	
	40	5	320	55.1	39	120.2	401	69.0	41	147.1	483	83.1	40	181.4	588	101.2	52	220.8
		6	331	56.9	42	121.1	415	71.4	43	148.4	500	86.0	42	182.9	608	104.6	55	222.6
		7	342	58.8	45	122.1	429	73.7	45	149.6	516	88.8	45	184.4	629	108.1	58	224.4
		8	353	60.7	48	123.1	442	76.1	48	150.8	533	91.7	47	185.9	649	111.6	61	226.3
9		364	62.6	51	124.1	456	78.5	50	152.0	550	94.5	50	187.4	669	115.0	64	228.1	
10		375	64.5	53	125.1	470	80.8	53	153.2	566	97.4	53	188.9	689	118.5	67	229.9	
11		386	66.4	57	126.1	484	83.2	55	154.5	583	100.2	55	190.4	709	122.0	70	231.8	
12		397	68.3	60	127.1	498	85.6	58	155.7	599	103.1	58	191.9	729	125.4	73	233.6	
13		408	70.1	63	128.1	511	87.9	60	156.9	616	105.9	61	193.4	749	128.9	77	235.4	
14		419	72.0	66	129.1	525	90.3	63	158.1	632	108.8	64	194.9	770	132.4	80	237.2	
15		430	73.9	70	130.1	539	92.7	66	159.3	649	111.6	67	196.4	790	135.8	83	239.1	
43		5	316	54.4	39	129.4	396	68.2	40	158.5	477	82.1	39	195.4	581	99.9	51	237.8
		6	326	56.1	41	130.1	409	70.4	42	159.3	493	84.8	41	196.4	600	103.2	54	239.1
		7	337	57.9	43	130.8	422	72.6	44	160.2	508	87.4	43	197.5	619	106.4	56	240.4
		8	347	59.7	46	131.5	435	74.8	46	161.1	524	90.1	46	198.5	637	109.6	59	241.6
	9	357	61.4	49	132.2	448	77.0	49	161.9	539	92.7	48	199.6	656	112.9	62	242.9	
	10	367	63.2	51	132.9	460	79.2	51	162.8	555	95.4	51	200.7	675	116.1	65	244.2	
	11	378	64.9	54	133.6	473	81.4	53	163.6	570	98.1	53	201.7	694	119.3	68	245.5	
	12	388	66.7	57	134.3	486	83.6	56	164.5	586	100.7	56	202.8	713	122.6	71	246.8	
	13	398	68.5	60	135.0	499	85.8	58	165.4	601	103.4	58	203.8	731	125.8	74	248.1	
	14	408	70.2	63	135.7	512	88.0	60	166.2	617	106.0	61	204.9	750	129.0	77	249.4	
	15	419	72.0	66	136.4	525	90.2	63	167.1	632	108.7	64	206.0	769	132.3	80	250.7	

ABT: Condensate Air Inlet Temperature (°C)
 CCAP: Cooling Capacity (kW)
 CPD: Water Cooler Pressure Drop (kPa)

CLOT: Chilled Water Outlet Temperature (°C)
 CFR: Chilled Water Flow Rate at 5 °C Difference Between Inlet and Outlet Temperature(m³/h)
 IPT: Input Power for Unit (kW)

Conversion Multiplier: 1kW=860kcal/h
 =3412Btu/h
 1kPa=0.102mAq

ABT	COT	RCUF200AZY1						RCUF220AZY1						RCUF240AZY1						
		CCAP	CFR1	CFR2	CPD1	CPD2	IPT	CCAP	CFR1	CFR2	CPD1	CPD2	IPT	CCAP	CFR1	CFR2	CPD1	CPD2	IPT	
25	5	679	58.4	58.4	44	44	147.8	765	73.2	58.4	45	44	166.5	852	73.2	73.2	45	45	185.2	
	6	709	60.9	60.9	48	48	152.7	798	76.4	60.9	48	48	172.1	888	76.4	76.4	48	48	191.4	
	7	738	63.5	63.5	52	52	157.6	831	79.6	63.5	51	52	177.6	925	79.6	79.6	51	51	197.6	
	8	767	66.0	66.0	56	56	162.6	864	82.7	66.0	55	56	183.2	962	82.7	82.7	55	55	203.8	
	9	796	68.5	68.5	60	60	167.5	897	85.9	68.5	58	60	188.7	998	85.9	85.9	58	58	209.9	
	10	826	71.0	71.0	64	64	172.4	930	89.0	71.0	61	64	194.3	1035	89.0	89.0	61	61	216.1	
	11	855	73.5	73.5	69	69	177.3	963	92.2	73.5	65	69	199.8	1072	92.2	92.2	65	65	222.3	
	12	884	76.1	76.1	73	73	182.3	996	95.3	76.1	69	73	205.4	1109	95.3	95.3	69	69	228.5	
	13	914	78.6	78.6	78	78	187.2	1029	98.5	78.6	72	78	210.9	1145	98.5	98.5	72	72	234.7	
	14	943	81.1	81.1	83	83	192.1	1062	101.7	81.1	76	83	216.5	1182	101.7	101.7	76	76	240.8	
	15	972	83.6	83.6	88	88	197.1	1095	104.8	83.6	80	88	222.0	1219	104.8	104.8	80	80	247.0	
	30	5	666	57.3	57.3	43	43	178.6	751	71.8	57.3	43	43	201.3	835	71.8	71.8	43	43	223.9
		6	693	59.6	59.6	46	46	182.6	781	74.7	59.6	46	46	205.7	869	74.7	74.7	46	46	228.8
		7	720	61.9	61.9	49	49	186.5	811	77.6	61.9	49	49	210.2	903	77.6	77.6	49	49	233.8
		8	747	64.2	64.2	53	53	190.5	841	80.5	64.2	52	53	214.6	936	80.5	80.5	52	52	238.7
9		774	66.5	66.5	57	57	194.4	872	83.4	66.5	55	57	219.1	970	83.4	83.4	55	55	243.7	
10		800	68.8	68.8	61	61	198.4	902	86.3	68.8	58	61	223.5	1003	86.3	86.3	58	58	248.6	
11		827	71.1	71.1	65	65	202.3	932	89.2	71.1	62	65	228.0	1037	89.2	89.2	62	62	253.6	
12		854	73.5	73.5	69	69	206.3	962	92.1	73.5	65	69	232.4	1071	92.1	92.1	65	65	258.5	
13		881	75.8	75.8	73	73	210.2	993	95.0	75.8	68	73	236.9	1104	95.0	95.0	68	68	263.5	
14		908	78.1	78.1	77	77	214.2	1023	97.9	78.1	72	77	241.3	1138	97.9	97.9	72	72	268.4	
15		935	80.4	80.4	82	82	218.1	1053	100.8	80.4	75	82	245.8	1172	100.8	100.8	75	75	273.4	
35		5	653	56.2	56.2	41	41	209.5	736	70.4	56.2	42	41	236.0	819	70.4	70.4	42	42	262.6
		6	678	58.3	58.3	44	44	212.4	764	73.1	58.3	45	44	239.4	849	73.1	73.1	45	45	266.3
		7	702	60.4	60.4	46	46	215.3	791	75.7	60.4	46	46	242.6	880	75.7	75.7	46	46	269.9
		8	726	62.5	62.5	50	50	218.4	818	78.3	62.5	50	50	246.0	911	78.3	78.3	50	50	273.7
	9	751	64.6	64.6	54	54	221.3	846	80.9	64.6	53	54	249.4	941	80.9	80.9	53	53	277.4	
	10	775	66.7	66.7	57	57	224.3	873	83.6	66.7	55	57	252.7	972	83.6	83.6	55	55	281.2	
	11	800	68.8	68.8	61	61	227.3	901	86.2	68.8	58	61	256.1	1002	86.2	86.2	58	58	284.9	
	12	824	70.9	70.9	64	64	230.2	928	88.8	70.9	61	64	259.4	1033	88.8	88.8	61	61	288.6	
	13	848	73.0	73.0	68	68	233.2	956	91.5	73.0	64	68	262.8	1063	91.5	91.5	64	64	292.3	
	14	873	75.1	75.1	72	72	236.2	983	94.1	75.1	67	72	266.1	1094	94.1	94.1	67	67	296.1	
	15	897	77.2	77.2	75	75	239.2	1011	96.7	77.2	70	75	269.5	1125	96.7	96.7	70	70	299.8	
	40	5	640	55.1	55.1	39	39	240.3	721	69.0	55.1	41	39	267.3	802	69.0	69.0	41	41	294.3
		6	662	56.9	56.9	42	42	242.3	746	71.4	56.9	43	42	269.5	830	71.4	71.4	43	43	296.7
		7	684	58.8	58.8	45	45	244.3	771	73.7	58.8	45	45	271.7	857	73.7	73.7	45	45	299.2
		8	706	60.7	60.7	48	48	246.3	795	76.1	60.7	48	48	273.9	885	76.1	76.1	48	48	301.6
9		728	62.6	62.6	51	51	248.3	820	78.5	62.6	50	51	276.2	912	78.5	78.5	50	50	304.1	
10		750	64.5	64.5	53	53	250.3	845	80.8	64.5	53	53	278.4	940	80.8	80.8	53	53	306.5	
11		772	66.4	66.4	57	57	252.2	870	83.2	66.4	55	57	280.6	968	83.2	83.2	55	55	308.9	
12		794	68.3	68.3	60	60	254.2	894	85.6	68.3	58	60	282.8	995	85.6	85.6	58	58	311.4	
13		816	70.1	70.1	63	63	256.2	919	87.9	70.1	60	63	285.0	1023	87.9	87.9	60	60	313.8	
14		838	72.0	72.0	66	66	258.2	944	90.3	72.0	63	66	287.2	1050	90.3	90.3	63	63	316.2	
15		860	73.9	73.9	70	70	260.2	969	92.7	73.9	66	70	289.4	1078	92.7	92.7	66	66	318.7	
43		5	632	54.4	54.4	39	39	258.8	712	68.2	54.4	40	39	287.9	793	68.2	68.2	40	40	317.0
		6	653	56.1	56.1	41	41	260.2	736	70.4	56.1	42	41	289.4	818	70.4	70.4	42	42	318.7
		7	673	57.9	57.9	43	43	261.6	759	72.6	57.9	44	43	291.0	844	72.6	72.6	44	44	320.4
		8	694	59.7	59.7	46	46	263.0	782	74.8	59.7	46	46	292.6	870	74.8	74.8	46	46	322.1
	9	714	61.4	61.4	49	49	264.4	805	77.0	61.4	49	49	294.1	895	77.0	77.0	49	49	323.8	
	10	735	63.2	63.2	51	51	265.8	828	79.2	63.2	51	51	295.7	921	79.2	79.2	51	51	325.6	
	11	755	64.9	64.9	54	54	267.2	851	81.4	64.9	53	54	297.3	947	81.4	81.4	53	53	327.3	
	12	776	66.7	66.7	57	57	268.6	874	83.6	66.7	56	57	298.8	972	83.6	83.6	56	56	329.0	
	13	796	68.5	68.5	60	60	270.0	897	85.8	68.5	58	60	300.4	998	85.8	85.8	58	58	330.7	
	14	817	70.2	70.2	63	63	271.4	920	88.0	70.2	60	63	301.9	1024	88.0	88.0	60	60	332.4	
	15	837	72.0	72.0	66	66	272.8	943	90.2	72.0	63	66	303.5	1049	90.2	90.2	63	63	334.1	

ABT: Condensate Air Inlet Temperature (°C)

CLOT: Chilled Water Outlet Temperature (°C)

CCAP: Cooling Capacity (kW)

CFR1,CFR2: Chilled Water Flow Rate of No.1 Unit and No.2 Unit at 5 °C Difference Between Inlet and Outlet Temperature (m³/h).

CPD1,CPD2: Water Cooler Pressure Drop of No.1 Unit and No.2 Unit (kPa)

IPT: Input Power for Unit (kW)

Conversion Multiplier: 1kW=860kcal/h
=3412Btu/h
1kPa=0.102mAq

ABT	COT	RCUF270AZY1						RCUF300AZY1						RCUF330AZY1						
		CCAP	CFR1	CFR2	CPD1	CPD2	IPT	CCAP	CFR1	CFR2	CPD1	CPD2	IPT	CCAP	CFR1	CFR2	CPD1	CPD2	IPT	
25	5	939	88.2	73.2	44	45	204.2	1026	88.2	88.2	44	44	223.1	1137	107.4	88.2	57	44	247.3	
	6	979	92.0	76.4	48	48	211.0	1070	92.0	92.0	48	48	230.5	1186	112.0	92.0	61	48	255.6	
	7	1020	95.8	79.6	51	51	217.8	1114	95.8	95.8	51	51	238.0	1235	116.6	95.8	65	51	263.8	
	8	1060	99.6	82.7	55	55	224.6	1158	99.6	99.6	55	55	245.4	1284	121.2	99.6	69	55	272.1	
	9	1101	103.4	85.9	58	58	231.4	1203	103.4	103.4	58	58	252.9	1333	125.9	103.4	74	58	280.3	
	10	1141	107.2	89.0	62	61	238.2	1247	107.2	107.2	62	62	260.3	1382	130.5	107.2	78	62	288.6	
	11	1182	111.0	92.2	66	65	245.0	1291	111.0	111.0	66	66	267.7	1431	135.1	111.0	83	66	296.8	
	12	1222	114.8	95.3	70	69	251.8	1335	114.8	114.8	70	70	275.2	1480	139.8	114.8	87	70	305.1	
	13	1262	118.6	98.5	75	72	258.6	1380	118.6	118.6	75	75	282.6	1529	144.4	118.6	92	75	313.3	
	14	1303	122.4	101.7	79	76	265.5	1424	122.4	122.4	79	79	290.1	1578	149.0	122.4	97	79	321.6	
	15	1343	126.3	104.8	83	80	272.3	1468	126.3	126.3	83	83	297.5	1627	153.6	126.3	101	83	329.8	
	30	5	921	86.5	71.8	43	43	246.8	1006	86.5	86.5	43	43	269.7	1115	105.3	86.5	55	43	298.9
		6	958	90.0	74.7	46	46	252.2	1047	90.0	90.0	46	46	275.6	1160	109.5	90.0	59	46	305.6
		7	995	93.5	77.6	49	49	257.7	1087	93.5	93.5	49	49	281.6	1205	113.8	93.5	63	49	312.2
		8	1032	97.0	80.5	52	52	263.2	1128	97.0	97.0	52	52	287.6	1250	118.0	97.0	67	52	318.8
9		1069	100.5	83.4	56	55	268.6	1168	100.5	100.5	56	56	293.5	1295	122.3	100.5	70	56	325.4	
10		1106	103.9	86.3	59	58	274.1	1209	103.9	103.9	59	59	299.5	1340	126.5	103.9	74	59	332.0	
11		1143	107.4	89.2	63	62	279.5	1249	107.4	107.4	63	63	305.4	1385	130.7	107.4	78	63	338.6	
12		1180	110.9	92.1	66	65	285.0	1290	110.9	110.9	66	66	311.4	1430	135.0	110.9	82	66	345.2	
13		1217	114.4	95.0	70	68	290.4	1330	114.4	114.4	70	70	317.4	1475	139.2	114.4	87	70	351.8	
14		1254	117.9	97.9	74	72	295.9	1371	117.9	117.9	74	74	323.3	1520	143.5	117.9	91	74	358.4	
15		1291	121.4	100.8	78	75	301.3	1411	121.4	121.4	78	78	329.3	1564	147.7	121.4	95	78	365.0	
35		5	903	84.8	70.4	41	42	289.4	986	84.8	84.8	41	41	316.2	1093	103.2	84.8	54	41	350.6
		6	936	88.0	73.1	44	45	293.5	1023	88.0	88.0	44	44	320.7	1134	107.1	88.0	57	44	355.5
		7	970	91.2	75.7	46	46	297.5	1060	91.2	91.2	46	46	325.2	1175	110.9	91.2	60	46	360.4
		8	1004	94.3	78.3	50	50	301.7	1097	94.3	94.3	50	50	329.7	1216	114.8	94.3	64	50	365.5
	9	1037	97.5	80.9	53	53	305.8	1134	97.5	97.5	53	53	334.2	1257	118.6	97.5	67	53	370.4	
	10	1071	100.7	83.6	56	55	309.9	1170	100.7	100.7	56	56	338.7	1297	122.5	100.7	71	56	375.4	
	11	1105	103.8	86.2	59	58	314.0	1207	103.8	103.8	59	59	343.1	1338	126.4	103.8	74	59	380.4	
	12	1139	107.0	88.8	62	61	318.1	1244	107.0	107.0	62	62	347.6	1379	130.2	107.0	78	62	385.4	
	13	1172	110.2	91.5	65	64	322.2	1281	110.2	110.2	65	65	352.1	1420	134.1	110.2	82	65	390.3	
	14	1206	113.3	94.1	69	67	326.3	1318	113.3	113.3	69	69	356.6	1461	137.9	113.3	85	69	395.3	
	15	1240	116.5	96.7	72	70	330.4	1355	116.5	116.5	72	72	361.1	1502	141.8	116.5	89	72	400.3	
	40	5	885	83.1	69.0	40	41	328.5	967	83.1	83.1	40	40	362.8	1071	101.2	83.1	52	40	402.2
		6	915	86.0	71.4	42	43	331.3	1000	86.0	86.0	42	42	365.8	1108	104.6	86.0	55	42	405.5
		7	945	88.8	73.7	45	45	334.0	1033	88.8	88.8	45	45	368.8	1145	108.1	88.8	58	45	408.8
		8	976	91.7	76.1	47	48	336.7	1066	91.7	91.7	47	47	371.8	1182	111.6	91.7	61	47	412.2
9		1006	94.5	78.5	50	50	339.4	1099	94.5	94.5	50	50	374.8	1218	115.0	94.5	64	50	415.5	
10		1036	97.4	80.8	53	53	342.2	1132	97.4	97.4	53	53	377.8	1255	118.5	97.4	67	53	418.8	
11		1066	100.2	83.2	55	55	344.9	1165	100.2	100.2	55	55	380.8	1292	122.0	100.2	70	55	422.2	
12		1097	103.1	85.6	58	58	347.6	1199	103.1	103.1	58	58	383.8	1329	125.4	103.1	73	58	425.5	
13		1127	105.9	87.9	61	60	350.3	1232	105.9	105.9	61	61	386.8	1365	128.9	105.9	77	61	428.8	
14		1157	108.8	90.3	64	63	353.0	1265	108.8	108.8	64	64	389.8	1402	132.4	108.8	80	64	432.2	
15		1188	111.6	92.7	67	66	355.8	1298	111.6	111.6	67	67	392.9	1439	135.8	111.6	83	67	435.5	
43		5	874	82.1	68.2	39	40	353.8	955	82.1	82.1	39	39	390.7	1058	99.9	82.1	51	39	433.1
		6	902	84.8	70.4	41	42	355.8	986	84.8	84.8	41	41	392.9	1093	103.2	84.8	54	41	435.5
		7	930	87.4	72.6	43	44	357.7	1017	87.4	87.4	43	43	395.0	1127	106.4	87.4	56	43	437.8
		8	959	90.1	74.8	46	46	359.6	1048	90.1	90.1	46	46	397.1	1161	109.6	90.1	59	46	440.2
	9	987	92.7	77.0	48	49	361.5	1078	92.7	92.7	48	48	399.2	1195	112.9	92.7	62	48	442.5	
	10	1015	95.4	79.2	51	51	363.4	1109	95.4	95.4	51	51	401.3	1230	116.1	95.4	65	51	444.9	
	11	1043	98.1	81.4	53	53	365.4	1140	98.1	98.1	53	53	403.4	1264	119.3	98.1	68	53	447.2	
	12	1072	100.7	83.6	56	56	367.3	1171	100.7	100.7	56	56	405.6	1298	122.6	100.7	71	56	449.6	
	13	1100	103.4	85.8	58	58	369.2	1202	103.4	103.4	58	58	407.7	1333	125.8	103.4	74	58	451.9	
	14	1128	106.0	88.0	61	60	371.1	1233	106.0	106.0	61	61	409.8	1367	129.0	106.0	77	61	454.3	
	15	1157	108.7	90.2	64	63	373.0	1264	108.7	108.7	64	64	411.9	1401	132.3	108.7	80	64	456.6	

ABT: Condensate Air Inlet Temperature (°C)

CLOT: Chilled Water Outlet Temperature (°C)

CCAP: Cooling Capacity (kW)

CFR1,CFR2: Chilled Water Flow Rate of No.1 Unit and No.2 Unit at 5 °C Difference Between Inlet and Outlet Temperature (m³/h).

CPD1,CPD2: Water Cooler Pressure Drop of No.1 Unit and No.2 Unit (kPa)

IPT: Input Power for Unit (kW)

Conversion Multiplier : 1kW=860kcal/h
 =3412Btu/h
 1kPa=0.102mAq

ABT	COT	RCUF360AZY1						RCUF400AZY1							
		CCAP	CFR1	CFR2	CPD1	CPD2	IPT	CCAP	CFR1	CFR2	CFR3	CPD1	CPD2	CPD3	IPT
25	5	1248	107.4	107.4	57	57	271.5	1365	88.2	88.2	58.4	44	44	44	297.0
	6	1302	112.0	112.0	61	61	280.6	1424	92.0	92.0	60.9	48	48	48	306.9
	7	1356	116.6	116.6	65	65	289.7	1483	95.8	95.8	63.5	51	51	52	316.8
	8	1410	121.2	121.2	69	69	298.7	1542	99.6	99.6	66.0	55	55	56	326.7
	9	1464	125.9	125.9	74	74	307.8	1601	103.4	103.4	68.5	58	58	60	336.6
	10	1517	130.5	130.5	78	78	316.8	1660	107.2	107.2	71.0	62	62	64	346.5
	11	1571	135.1	135.1	83	83	325.9	1719	111.0	111.0	73.5	66	66	69	356.4
	12	1625	139.8	139.8	87	87	334.9	1778	114.8	114.8	76.1	70	70	73	366.3
	13	1679	144.4	144.4	92	92	344.0	1836	118.6	118.6	78.6	75	75	78	376.2
	14	1733	149.0	149.0	97	97	353.0	1895	122.4	122.4	81.1	79	79	83	386.1
15	1787	153.6	153.6	101	101	362.1	1954	126.3	126.3	83.6	83	83	88	396.0	
30	5	1224	105.3	105.3	55	55	328.2	1339	86.5	86.5	57.3	43	43	43	359.0
	6	1274	109.5	109.5	59	59	335.5	1393	90.0	90.0	59.6	46	46	46	366.9
	7	1323	113.8	113.8	63	63	342.7	1447	93.5	93.5	61.9	49	49	49	374.9
	8	1372	118.0	118.0	67	67	350.0	1501	97.0	97.0	64.2	52	52	53	382.8
	9	1422	122.3	122.3	70	70	357.2	1555	100.5	100.5	66.5	56	56	57	390.7
	10	1471	126.5	126.5	74	74	364.5	1609	103.9	103.9	68.8	59	59	61	398.7
	11	1520	130.7	130.7	78	78	371.8	1663	107.4	107.4	71.1	63	63	65	406.6
	12	1570	135.0	135.0	82	82	379.0	1717	110.9	110.9	73.5	66	66	69	414.5
	13	1619	139.2	139.2	87	87	386.3	1771	114.4	114.4	75.8	70	70	73	422.5
	14	1668	143.5	143.5	91	91	393.5	1825	117.9	117.9	78.1	74	74	77	430.4
15	1718	147.7	147.7	95	95	400.8	1879	121.4	121.4	80.4	78	78	82	438.3	
35	5	1200	103.2	103.2	54	54	384.9	1313	84.8	84.8	56.2	41	41	41	421.0
	6	1245	107.1	107.1	57	57	390.3	1362	88.0	88.0	58.3	44	44	44	426.9
	7	1290	110.9	110.9	60	60	395.7	1411	91.2	91.2	60.4	46	46	46	432.8
	8	1335	114.8	114.8	64	64	401.3	1460	94.3	94.3	62.5	50	50	50	438.9
	9	1380	118.6	118.6	67	67	406.7	1509	97.5	97.5	64.6	53	53	54	444.8
	10	1424	122.5	122.5	71	71	412.2	1558	100.7	100.7	66.7	56	56	57	450.8
	11	1469	126.4	126.4	74	74	417.6	1607	103.8	103.8	68.8	59	59	61	456.8
	12	1514	130.2	130.2	78	78	423.1	1656	107.0	107.0	70.9	62	62	64	462.7
	13	1559	134.1	134.1	82	82	428.5	1705	110.2	110.2	73.0	65	65	68	468.7
	14	1604	137.9	137.9	85	85	434.0	1754	113.3	113.3	75.1	69	69	72	474.7
15	1649	141.8	141.8	89	89	439.5	1803	116.5	116.5	77.2	72	72	75	480.7	
40	5	1176	101.2	101.2	52	52	441.6	1287	83.1	83.1	55.1	40	40	39	482.9
	6	1217	104.6	104.6	55	55	445.2	1331	86.0	86.0	56.9	42	42	42	486.9
	7	1257	108.1	108.1	58	58	448.9	1375	88.8	88.8	58.8	45	45	45	490.9
	8	1297	111.6	111.6	61	61	452.5	1419	91.7	91.7	60.7	47	47	48	494.9
	9	1338	115.0	115.0	64	64	456.2	1463	94.5	94.5	62.6	50	50	51	499.0
	10	1378	118.5	118.5	67	67	459.8	1507	97.4	97.4	64.5	53	53	53	503.0
	11	1418	122.0	122.0	70	70	463.5	1551	100.2	100.2	66.4	55	55	57	507.0
	12	1459	125.4	125.4	73	73	467.2	1595	103.1	103.1	68.3	58	58	60	511.0
	13	1499	128.9	128.9	77	77	470.8	1640	105.9	105.9	70.1	61	61	63	515.0
	14	1539	132.4	132.4	80	80	474.5	1684	108.8	108.8	72.0	64	64	66	519.0
15	1580	135.8	135.8	83	83	478.1	1728	111.6	111.6	73.9	67	67	70	523.0	
43	5	1162	99.9	99.9	51	51	475.6	1271	82.1	82.1	54.4	39	39	39	520.1
	6	1200	103.2	103.2	54	54	478.1	1312	84.8	84.8	56.1	41	41	41	523.0
	7	1237	106.4	106.4	56	56	480.7	1353	87.4	87.4	57.9	43	43	43	525.8
	8	1275	109.6	109.6	59	59	483.3	1394	90.1	90.1	59.7	46	46	46	528.6
	9	1312	112.9	112.9	62	62	485.9	1436	92.7	92.7	61.4	48	48	49	531.4
	10	1350	116.1	116.1	65	65	488.5	1477	95.4	95.4	63.2	51	51	51	534.2
	11	1388	119.3	119.3	68	68	491.0	1518	98.1	98.1	64.9	53	53	54	537.1
	12	1425	122.6	122.6	71	71	493.6	1559	100.7	100.7	66.7	56	56	57	539.9
	13	1463	125.8	125.8	74	74	496.2	1600	103.4	103.4	68.5	58	58	60	542.7
	14	1501	129.0	129.0	77	77	498.8	1641	106.0	106.0	70.2	61	61	63	545.5
15	1538	132.3	132.3	80	80	501.3	1682	108.7	108.7	72.0	64	64	66	548.3	

ABT: Condensate Air Inlet Temperature (°C)

CLOT: Chilled Water Outlet Temperature (°C)

CCAP: Cooling Capacity (kW)

CFR1,CFR2,CFR3: Chilled Water Flow Rate of No.1 Unit No.2 Unit and No.3 Unit at 5 °C Difference Between Inlet and Outlet Temperature (m³/h).

CPD1,CPD2,CPD3: Water Cooler Pressure Drop of No.1 Unit No.2 Unit and No.3 Unit (kPa)

IPT: Input Power for Unit (kW)

Conversion Multiplier: 1kW=860kcal/h
 =3412Btu/h
 1kPa=0.102mAq

ABT	COT	RCUF420AZY1								RCUF450AZY1							
		CCAP	CFR1	CFR2	CFR3	CPD1	CPD2	CPD3	IPT	CCAP	CFR1	CFR2	CFR3	CPD1	CPD2	CPD3	IPT
25	5	1452	88.2	88.2	73.2	44	44	45	315.7	1539	88.2	88.2	88.2	44	44	44	334.7
	6	1514	92.0	92.0	76.4	48	48	48	326.3	1605	92.0	92.0	92.0	48	48	48	345.8
	7	1577	95.8	95.8	79.6	51	51	51	336.8	1671	95.8	95.8	95.8	51	51	51	357.0
	8	1639	99.6	99.6	82.7	55	55	55	347.3	1738	99.6	99.6	99.6	55	55	55	368.1
	9	1702	103.4	103.4	85.9	58	58	58	357.8	1804	103.4	103.4	103.4	58	58	58	379.3
	10	1764	107.2	107.2	89.0	62	62	61	368.4	1870	107.2	107.2	107.2	62	62	62	390.5
	11	1827	111.0	111.0	92.2	66	66	65	378.9	1937	111.0	111.0	111.0	66	66	66	401.6
	12	1890	114.8	114.8	95.3	70	70	69	389.4	2003	114.8	114.8	114.8	70	70	70	412.8
	13	1952	118.6	118.6	98.5	75	75	72	400.0	2069	118.6	118.6	118.6	75	75	75	423.9
	14	2015	122.4	122.4	101.7	79	79	76	410.5	2136	122.4	122.4	122.4	79	79	79	435.1
15	2077	126.3	126.3	104.8	83	83	80	421.0	2202	126.3	126.3	126.3	83	83	83	446.3	
30	5	1424	86.5	86.5	71.8	43	43	43	381.6	1509	86.5	86.5	86.5	43	43	43	404.5
	6	1481	90.0	90.0	74.7	46	46	46	390.1	1570	90.0	90.0	90.0	46	46	46	413.4
	7	1538	93.5	93.5	77.6	49	49	49	398.5	1631	93.5	93.5	93.5	49	49	49	422.4
	8	1596	97.0	97.0	80.5	52	52	52	406.9	1691	97.0	97.0	97.0	52	52	52	431.3
	9	1653	100.5	100.5	83.4	56	56	55	415.4	1752	100.5	100.5	100.5	56	56	56	440.3
	10	1710	103.9	103.9	86.3	59	59	58	423.8	1813	103.9	103.9	103.9	59	59	59	449.2
	11	1768	107.4	107.4	89.2	63	63	62	432.2	1874	107.4	107.4	107.4	63	63	63	458.2
	12	1825	110.9	110.9	92.1	66	66	65	440.7	1935	110.9	110.9	110.9	66	66	66	467.1
	13	1882	114.4	114.4	95.0	70	70	68	449.1	1995	114.4	114.4	114.4	70	70	70	476.0
	14	1940	117.9	117.9	97.9	74	74	72	457.6	2056	117.9	117.9	117.9	74	74	74	485.0
15	1997	121.4	121.4	100.8	78	78	75	466.0	2117	121.4	121.4	121.4	78	78	78	493.9	
35	5	1396	84.8	84.8	70.4	41	41	42	447.5	1480	84.8	84.8	84.8	41	41	41	474.3
	6	1448	88.0	88.0	73.1	44	44	45	453.9	1535	88.0	88.0	88.0	44	44	44	481.1
	7	1500	91.2	91.2	75.7	46	46	46	460.1	1590	91.2	91.2	91.2	46	46	46	487.7
	8	1552	94.3	94.3	78.3	50	50	50	466.5	1645	94.3	94.3	94.3	50	50	50	494.5
	9	1604	97.5	97.5	80.9	53	53	53	472.9	1700	97.5	97.5	97.5	53	53	53	501.3
	10	1656	100.7	100.7	83.6	56	56	55	479.2	1756	100.7	100.7	100.7	56	56	56	508.0
	11	1708	103.8	103.8	86.2	59	59	58	485.6	1811	103.8	103.8	103.8	59	59	59	514.7
	12	1761	107.0	107.0	88.8	62	62	61	491.9	1866	107.0	107.0	107.0	62	62	62	521.4
	13	1813	110.2	110.2	91.5	65	65	64	498.3	1921	110.2	110.2	110.2	65	65	65	528.2
	14	1865	113.3	113.3	94.1	69	69	67	504.6	1977	113.3	113.3	113.3	69	69	69	534.9
15	1917	116.5	116.5	96.7	72	72	70	511.0	2032	116.5	116.5	116.5	72	72	72	541.6	
40	5	1368	83.1	83.1	69.0	40	40	41	509.9	1450	83.1	83.1	83.1	40	40	40	544.2
	6	1415	86.0	86.0	71.4	42	42	43	514.2	1500	86.0	86.0	86.0	42	42	42	548.7
	7	1462	88.8	88.8	73.7	45	45	45	518.4	1549	88.8	88.8	88.8	45	45	45	553.2
	8	1509	91.7	91.7	76.1	47	47	48	522.6	1599	91.7	91.7	91.7	47	47	47	557.7
	9	1555	94.5	94.5	78.5	50	50	50	526.8	1649	94.5	94.5	94.5	50	50	50	562.2
	10	1602	97.4	97.4	80.8	53	53	53	531.1	1698	97.4	97.4	97.4	53	53	53	566.7
	11	1649	100.2	100.2	83.2	55	55	55	535.3	1748	100.2	100.2	100.2	55	55	55	571.2
	12	1696	103.1	103.1	85.6	58	58	58	539.5	1798	103.1	103.1	103.1	58	58	58	575.8
	13	1743	105.9	105.9	87.9	61	61	60	543.7	1848	105.9	105.9	105.9	61	61	61	580.3
	14	1790	108.8	108.8	90.3	64	64	63	548.0	1897	108.8	108.8	108.8	64	64	64	584.8
15	1837	111.6	111.6	92.7	67	67	66	552.2	1947	111.6	111.6	111.6	67	67	67	589.3	
43	5	1351	82.1	82.1	68.2	39	39	40	549.2	1432	82.1	82.1	82.1	39	39	39	586.1
	6	1395	84.8	84.8	70.4	41	41	42	552.2	1479	84.8	84.8	84.8	41	41	41	589.3
	7	1439	87.4	87.4	72.6	43	43	44	555.2	1525	87.4	87.4	87.4	43	43	43	592.5
	8	1482	90.1	90.1	74.8	46	46	46	558.1	1571	90.1	90.1	90.1	46	46	46	595.6
	9	1526	92.7	92.7	77.0	48	48	49	561.1	1618	92.7	92.7	92.7	48	48	48	598.8
	10	1570	95.4	95.4	79.2	51	51	51	564.1	1664	95.4	95.4	95.4	51	51	51	602.0
	11	1614	98.1	98.1	81.4	53	53	53	567.1	1710	98.1	98.1	98.1	53	53	53	605.2
	12	1657	100.7	100.7	83.6	56	56	56	570.1	1757	100.7	100.7	100.7	56	56	56	608.3
	13	1701	103.4	103.4	85.8	58	58	58	573.0	1803	103.4	103.4	103.4	58	58	58	611.5
	14	1745	106.0	106.0	88.0	61	61	60	576.0	1850	106.0	106.0	106.0	61	61	61	614.7
15	1789	108.7	108.7	90.2	64	64	63	579.0	1896	108.7	108.7	108.7	64	64	64	617.9	

ABT: Condensate Air Inlet Temperature (°C)

CLOT: Chilled Water Outlet Temperature (°C)

CCAP: Cooling Capacity (kW)

CFR1,CFR2,CFR3: Chilled Water Flow Rate of No.1 Unit No.2 Unit and No.3 Unit at 5 °C Difference Between Inlet and Outlet Temperature (m³/h).

CPD1,CPD2,CPD3: Water Cooler Pressure Drop of No.1 Unit No.2 Unit and No.3 Unit (kPa)

IPT: Input Power for Unit (kW)

Conversion Multiplier: 1kW=860kcal/h
=3412Btu/h
1kPa=0.102mAq

ABT	COLT	RCUF45AZPY1				RCUF50AZPY1				RCUF60AZPY1				RCUF90AZPY1				
		CCAP	CFR	CPD	IPT	CCAP	CFR	CPD	IPT	CCAP	CFR	CPD	IPT	CCAP	CFR	CPD	IPT	
25	5	155	26.6	30	30.2	172	29.6	39	33.6	208	35.8	52	40.6	310	53.3	39	60.4	
	6	162	27.8	33	31.3	180	30.9	43	34.9	217	37.3	56	42.1	323	55.5	42	62.7	
	7	168	28.9	37	32.4	187	32.2	47	36.1	226	38.9	60	43.6	336	57.8	45	64.9	
	8	175	30.1	40	33.5	195	33.5	51	37.4	235	40.4	64	45.1	350	60.1	49	67.2	
	9	182	31.2	44	34.7	202	34.7	56	38.6	244	42.0	68	46.6	363	62.4	53	69.4	
	10	188	32.4	47	35.8	209	36.0	60	39.9	253	43.5	72	48.1	376	64.7	56	71.7	
	11	195	33.5	51	36.9	217	37.3	66	41.1	262	45.0	76	49.6	390	67.0	60	73.9	
	12	202	34.7	55	38.0	224	38.6	71	42.4	271	46.6	81	51.2	403	69.3	64	76.2	
	13	208	35.8	60	39.2	232	39.8	76	43.6	280	48.1	85	52.7	416	71.6	69	78.4	
	14	215	37.0	64	40.3	239	41.1	82	44.9	289	49.7	90	54.2	430	73.9	73	80.7	
	15	222	38.1	69	41.4	247	42.4	88	46.1	298	51.2	94	55.7	443	76.2	77	82.9	
	30	5	152	26.1	29	37.2	169	29.1	37	41.5	204	35.1	51	50.0	304	52.2	37	74.5
		6	158	27.2	32	38.1	176	30.2	41	42.5	212	36.5	54	51.2	316	54.3	40	76.3
		7	164	28.2	35	39.0	183	31.4	44	43.5	221	37.9	57	52.5	328	56.4	43	78.1
		8	170	29.3	38	39.9	189	32.6	48	44.5	229	39.3	61	53.7	340	58.5	47	79.9
9		176	30.3	41	40.8	196	33.7	52	45.5	237	40.8	65	54.9	353	60.6	50	81.7	
10		182	31.4	44	41.7	203	34.9	56	46.5	245	42.2	68	56.1	365	62.7	53	83.5	
11		189	32.4	48	42.6	210	36.1	61	47.5	253	43.6	72	57.3	377	64.8	57	85.3	
12		195	33.5	51	43.5	217	37.3	65	48.5	262	45.0	76	58.5	389	67.0	60	87.1	
13		201	34.5	55	44.4	223	38.4	70	49.5	270	46.4	80	59.7	401	69.1	64	88.9	
14		207	35.6	59	45.3	230	39.6	75	50.5	278	47.8	84	60.9	414	71.2	68	90.7	
15		213	36.6	63	46.2	237	40.8	80	51.5	286	49.2	88	62.1	426	73.3	72	92.5	
35		5	149	25.6	28	44.2	166	28.5	35	49.3	200	34.4	49	59.5	298	51.2	36	88.6
		6	154	26.6	30	44.9	172	29.6	38	50.0	208	35.7	52	60.4	309	53.1	39	89.9
		7	160	27.5	34	45.6	178	30.6	40	50.7	215	37.0	55	61.3	320	55.0	40	91.2
		8	166	28.5	38	46.3	184	31.7	45	51.5	222	38.3	58	62.2	331	56.9	44	92.6
	9	171	29.4	41	46.9	190	32.7	49	52.3	230	39.5	62	63.1	342	58.8	47	94.0	
	10	177	30.4	44	47.6	197	33.8	52	53.1	237	40.8	65	64.0	353	60.8	50	95.3	
	11	182	31.3	47	48.3	203	34.9	56	53.8	245	42.1	68	64.9	364	62.7	53	96.7	
	12	188	32.3	50	49.0	209	35.9	60	54.6	252	43.4	72	65.9	375	64.6	56	98.1	
	13	193	33.3	54	49.6	215	37.0	64	55.3	260	44.7	75	66.8	387	66.5	59	99.4	
	14	199	34.2	57	50.3	221	38.1	69	56.1	267	46.0	79	67.7	398	68.4	63	100.8	
	15	204	35.2	61	51.0	227	39.1	73	56.8	275	47.3	83	68.6	409	70.3	66	102.1	
	40	5	146	25.1	26	51.3	162	27.9	34	57.1	196	33.7	47	68.9	292	50.2	35	102.6
		6	151	26.0	29	51.7	168	28.9	36	57.6	203	34.9	50	69.5	302	51.9	37	103.5
		7	156	26.8	31	52.2	173	29.8	39	58.1	210	36.0	53	70.2	312	53.6	39	104.5
		8	161	27.7	33	52.6	179	30.8	42	58.6	216	37.2	56	70.8	322	55.3	42	105.4
9		166	28.5	36	53.1	185	31.7	45	59.1	223	38.3	58	71.4	332	57.1	44	106.3	
10		171	29.4	38	53.5	190	32.7	49	59.6	230	39.5	61	72.0	342	58.8	47	107.2	
11		176	30.3	41	54.0	196	33.7	52	60.1	236	40.7	64	72.6	352	60.5	50	108.1	
12		181	31.1	43	54.4	201	34.6	55	60.7	243	41.8	67	73.2	362	62.2	52	109.0	
13		186	32.0	46	54.9	207	35.6	59	61.2	250	43.0	71	73.8	372	63.9	55	109.9	
14		191	32.8	49	55.3	212	36.5	63	61.7	257	44.1	74	74.4	382	65.7	58	110.8	
15		196	33.7	52	55.8	218	37.5	66	62.2	263	45.3	77	75.0	392	67.4	61	111.7	
43		5	144	24.8	26	55.5	160	27.6	33	61.8	194	33.3	46	74.6	288	49.6	34	111.1
		6	149	25.6	28	55.8	166	28.5	35	62.2	200	34.4	49	75.0	297	51.2	36	111.7
		7	153	26.4	30	56.1	171	29.4	38	62.5	206	35.5	51	75.5	307	52.8	38	112.4
		8	158	27.2	32	56.4	176	30.3	41	62.9	212	36.5	54	75.9	316	54.4	40	113.0
	9	163	28.0	34	56.8	181	31.1	43	63.2	219	37.6	57	76.3	325	56.0	43	113.6	
	10	167	28.8	36	57.1	186	32.0	46	63.6	225	38.7	59	76.8	335	57.6	45	114.3	
	11	172	29.6	39	57.4	191	32.9	49	64.0	231	39.8	62	77.2	344	59.2	48	114.9	
	12	177	30.4	41	57.7	197	33.8	52	64.3	238	40.9	65	77.6	353	60.8	50	115.6	
	13	181	31.2	44	58.0	202	34.7	56	64.7	244	41.9	68	78.0	363	62.4	53	116.2	
	14	186	32.0	46	58.4	207	35.6	59	65.0	250	43.0	71	78.5	372	64.0	55	116.8	
	15	191	32.8	49	58.7	212	36.5	62	65.4	256	44.1	74	78.9	381	65.6	58	117.5	

ABT: Condensate Air Inlet Temperature (°C)
CCAP: Cooling Capacity (kW)
CPD: Water Cooler Pressure Drop (kPa)

CLOT: Chilled Water Outlet Temperature (°C)
CFR: Chilled Water Flow Rate at 5 °C Difference Between Inlet and Outlet Temperature (m³/h)
IPT: Input Power for Unit (kW)

Conversion Multiplier: 1kW=860kcal/h
=3412Btu/h
1kPa=0.102mAg

ABT	COT	RCUF100AZPY1				RCUF120AZPY1				RCUF135AZPY1				RCUF150AZPY1				
		CCAP	CFR	CPD	IPT	CCAP	CFR	CPD	IPT	CCAP	CFR	CPD	IPT	CCAP	CFR	CPD	IPT	
25	5	345	59.3	45	67.2	416	71.6	43	81.2	465	79.9	37	90.6	517	88.9	45	100.8	
	6	359	61.8	49	69.7	434	74.7	46	84.2	485	83.3	40	94.0	539	92.7	48	104.6	
	7	374	64.4	53	72.2	452	77.7	49	87.2	505	86.8	43	97.3	561	96.5	52	108.3	
	8	389	66.9	57	74.7	470	80.8	53	90.2	525	90.2	46	100.7	584	100.4	55	112.1	
	9	404	69.5	62	77.2	488	83.9	56	93.2	545	93.7	49	104.1	606	104.2	59	115.8	
	10	419	72.0	66	79.7	506	87.0	59	96.3	565	97.1	52	107.5	628	108.0	63	119.6	
	11	434	74.6	71	82.2	524	90.1	63	99.3	585	100.6	56	110.8	650	111.9	67	123.3	
	12	448	77.1	75	84.7	542	93.2	66	102.3	605	104.0	59	114.2	673	115.7	71	127.1	
	13	463	79.7	80	87.2	560	96.3	70	105.3	625	107.5	63	117.6	695	119.5	76	130.8	
	14	478	82.2	85	89.7	578	99.3	73	108.3	645	110.9	66	120.9	717	123.4	80	134.6	
	15	493	84.8	91	92.2	596	102.4	77	111.4	665	114.3	70	124.3	740	127.2	84	138.3	
	30	5	338	58.1	44	82.8	408	70.2	42	100.1	456	78.4	36	111.7	507	87.2	43	124.3
		6	351	60.5	47	84.8	425	73.0	45	102.5	474	81.5	38	114.4	527	90.7	46	127.3
		7	365	62.8	51	86.8	441	75.9	47	104.9	492	84.7	41	117.1	548	94.2	50	130.3
		8	379	65.1	55	88.8	457	78.7	50	107.3	511	87.8	44	119.8	568	97.7	53	133.3
9		392	67.5	58	90.8	474	81.5	53	109.7	529	91.0	47	122.5	588	101.2	56	136.3	
10		406	69.8	62	92.9	490	84.3	56	112.2	547	94.1	50	125.2	609	104.7	60	139.3	
11		420	72.2	66	94.9	507	87.2	59	114.6	566	97.3	52	127.9	629	108.2	63	142.3	
12		433	74.5	71	96.9	523	90.0	63	117.0	584	100.5	56	130.6	650	111.8	67	145.3	
13		447	76.8	75	98.9	540	92.8	66	119.4	602	103.6	59	133.3	670	115.3	71	148.3	
14		460	79.2	79	100.9	556	95.6	69	121.8	621	106.8	62	136.0	691	118.8	75	151.3	
15		474	81.5	84	102.9	573	98.5	72	124.3	639	109.9	65	138.7	711	122.3	79	154.3	
35		5	331	57.0	42	98.5	400	68.8	40	119.0	447	76.8	35	132.8	497	85.5	42	147.8
		6	344	59.1	45	100.0	415	71.4	43	120.8	463	79.7	37	134.8	515	88.7	45	150.0
		7	356	61.2	46	101.4	430	74.0	46	122.5	480	82.6	40	136.8	534	91.8	46	152.1
		8	368	63.4	52	103.0	445	76.5	48	124.4	497	85.4	42	138.9	553	95.0	50	154.5
	9	381	65.5	55	104.5	460	79.1	51	126.2	513	88.3	44	140.9	571	98.2	53	156.8	
	10	393	67.6	59	106.0	475	81.7	53	128.1	530	91.2	47	143.0	590	101.4	56	159.1	
	11	405	69.7	62	107.5	490	84.2	56	129.9	547	94.0	49	145.0	608	104.6	60	161.3	
	12	418	71.9	66	109.0	505	86.8	59	131.7	563	96.9	52	147.0	627	107.8	63	163.6	
	13	430	74.0	70	110.5	520	89.4	62	133.5	580	99.8	55	149.1	645	111.0	66	165.9	
	14	443	76.1	74	112.0	535	91.9	65	135.3	597	102.6	58	151.1	664	114.2	70	168.1	
	15	455	78.3	78	113.5	550	94.5	68	137.2	613	105.5	61	153.1	682	117.4	73	170.4	
	40	5	325	55.8	41	114.1	392	67.4	39	137.9	438	75.3	33	153.9	487	83.8	40	171.2
		6	336	57.8	43	115.1	406	69.8	41	139.1	453	77.9	35	155.3	504	86.6	43	172.8
		7	347	59.7	46	116.1	419	72.1	44	140.3	468	80.4	37	156.6	520	89.5	45	174.3
		8	358	61.6	49	117.2	432	74.4	46	141.5	483	83.0	40	158.0	537	92.4	48	175.8
9		369	63.5	52	118.2	446	76.7	48	142.7	498	85.6	42	159.3	554	95.2	51	177.3	
10		380	65.4	55	119.2	459	79.0	51	144.0	513	88.2	44	160.7	570	98.1	53	178.8	
11		391	67.3	58	120.2	473	81.3	53	145.2	528	90.8	46	162.1	587	101.0	56	180.3	
12		403	69.2	61	121.2	486	83.6	56	146.4	543	93.4	49	163.4	604	103.9	59	181.9	
13		414	71.1	65	122.2	500	85.9	58	147.6	558	95.9	51	164.8	620	106.7	62	183.4	
14		425	73.1	68	123.2	513	88.2	61	148.8	573	98.5	54	166.2	637	109.6	65	184.9	
15		436	75.0	71	124.2	527	90.6	63	150.1	588	101.1	56	167.5	654	112.5	68	186.4	
43		5	321	55.2	40	123.5	387	66.6	38	149.2	432	74.4	33	166.6	481	82.7	39	185.3
		6	331	56.9	42	124.2	400	68.8	40	150.1	446	76.8	35	167.5	497	85.4	42	186.4
		7	341	58.7	45	124.9	412	70.9	43	150.9	460	79.2	36	168.5	512	88.1	44	187.5
		8	352	60.5	47	125.7	425	73.1	45	151.8	474	81.6	38	169.4	528	90.8	46	188.5
	9	362	62.3	50	126.4	437	75.2	47	152.6	488	84.0	40	170.4	543	93.4	49	189.6	
	10	373	64.1	53	127.1	450	77.4	49	153.5	502	86.4	43	171.4	559	96.1	51	190.7	
	11	383	65.9	56	127.8	463	79.6	51	154.4	516	88.8	45	172.3	574	98.8	54	191.7	
	12	393	67.7	59	128.5	475	81.7	53	155.2	530	91.2	47	173.3	590	101.5	57	192.8	
	13	404	69.4	62	129.2	488	83.9	56	156.1	544	93.6	49	174.2	606	104.2	59	193.9	
	14	414	71.2	65	129.9	500	86.0	58	156.9	558	96.0	51	175.2	621	106.8	62	194.9	
	15	424	73.0	68	130.6	513	88.2	61	157.8	572	98.4	54	176.2	637	109.5	65	196.0	

ABT: Condensate Air Inlet Temperature (°C)
CCAP: Cooling Capacity (kW)
CPD: Water Cooler Pressure Drop (kPa)

CLOT: Chilled Water Outlet Temperature (°C)
CFR: Chilled Water Flow Rate at 5 °C Difference Between Inlet and Outlet Temperature (m³/h)
IPT: Input Power for Unit (kW)

Conversion Multiplier: 1kW=860kcal/h
=3412Btu/h
1kPa=0.102mAq

ABT	COT	RCUF180AZPY1						RCUF200AZPY1						RCUF240AZPY1						
		CCAP	CFR1	CFR2	CPD1	CPD2	IPT	CCAP	CFR1	CFR2	CPD1	CPD2	IPT	CCAP	CFR1	CFR2	CPD1	CPD2	IPT	
25	5	619	53.3	53.3	39	39	120.8	689	59.3	59.3	45	45	134.4	832	71.6	71.6	43	43	162.3	
	6	646	55.5	55.5	42	42	125.3	719	61.8	61.8	49	49	139.4	868	74.7	74.7	46	46	168.4	
	7	673	57.8	57.8	45	45	129.8	748	64.4	64.4	53	53	144.4	904	77.7	77.7	49	49	174.4	
	8	699	60.1	60.1	49	49	134.3	778	66.9	66.9	57	57	149.4	940	80.8	80.8	53	53	180.4	
	9	726	62.4	62.4	53	53	138.8	808	69.5	69.5	62	62	154.4	976	83.9	83.9	56	56	186.5	
	10	753	64.7	64.7	56	56	143.3	838	72.0	72.0	66	66	159.4	1012	87.0	87.0	59	59	192.5	
	11	779	67.0	67.0	60	60	147.8	867	74.6	74.6	71	71	164.4	1048	90.1	90.1	63	63	198.6	
	12	806	69.3	69.3	64	64	152.3	897	77.1	77.1	75	75	169.4	1083	93.2	93.2	66	66	204.6	
	13	833	71.6	71.6	69	69	156.8	927	79.7	79.7	80	80	174.4	1119	96.3	96.3	70	70	210.6	
	14	859	73.9	73.9	73	73	161.3	956	82.2	82.2	85	85	179.4	1155	99.3	99.3	73	73	216.7	
	15	886	76.2	76.2	77	77	165.8	986	84.8	84.8	91	91	184.4	1191	102.4	102.4	77	77	222.7	
	30	5	607	52.2	52.2	37	37	149.0	676	58.1	58.1	44	44	165.7	816	70.2	70.2	42	42	200.1
		6	632	54.3	54.3	40	40	152.6	703	60.5	60.5	47	47	169.7	849	73.0	73.0	45	45	205.0
		7	656	56.4	56.4	43	43	156.2	730	62.8	62.8	51	51	173.7	882	75.9	75.9	47	47	209.8
		8	681	58.5	58.5	47	47	159.8	757	65.1	65.1	55	55	177.7	915	78.7	78.7	50	50	214.6
9		705	60.6	60.6	50	50	163.4	785	67.5	67.5	58	58	181.7	948	81.5	81.5	53	53	219.5	
10		730	62.7	62.7	53	53	167.0	812	69.8	69.8	62	62	185.7	981	84.3	84.3	56	56	224.3	
11		754	64.8	64.8	57	57	170.6	839	72.2	72.2	66	66	189.7	1014	87.2	87.2	59	59	229.2	
12		779	67.0	67.0	60	60	174.2	866	74.5	74.5	71	71	193.7	1046	90.0	90.0	63	63	234.0	
13		803	69.1	69.1	64	64	177.8	894	76.8	76.8	75	75	197.7	1079	92.8	92.8	66	66	238.8	
14		827	71.2	71.2	68	68	181.4	921	79.2	79.2	79	79	201.7	1112	95.6	95.6	69	69	243.7	
15		852	73.3	73.3	72	72	185.0	948	81.5	81.5	84	84	205.7	1145	98.5	98.5	72	72	248.5	
35		5	595	51.2	51.2	36	36	177.1	663	57.0	57.0	42	42	197.0	800	68.8	68.8	40	40	237.9
		6	618	53.1	53.1	39	39	179.8	687	59.1	59.1	45	45	200.0	830	71.4	71.4	43	43	241.6
		7	640	55.0	55.0	40	40	182.4	712	61.2	61.2	46	46	202.8	860	74.0	74.0	46	46	245.0
		8	662	56.9	56.9	44	44	185.3	737	63.4	63.4	52	52	206.0	890	76.5	76.5	48	48	248.8
	9	684	58.8	58.8	47	47	188.0	761	65.5	65.5	55	55	209.0	920	79.1	79.1	51	51	252.5	
	10	707	60.8	60.8	50	50	190.7	786	67.6	67.6	59	59	212.0	950	81.7	81.7	53	53	256.1	
	11	729	62.7	62.7	53	53	193.4	811	69.7	69.7	62	62	215.0	980	84.2	84.2	56	56	259.8	
	12	751	64.6	64.6	56	56	196.1	836	71.9	71.9	66	66	218.1	1009	86.8	86.8	59	59	263.4	
	13	773	66.5	66.5	59	59	198.8	860	74.0	74.0	70	70	221.1	1039	89.4	89.4	62	62	267.0	
	14	795	68.4	68.4	63	63	201.5	885	76.1	76.1	74	74	224.1	1069	91.9	91.9	65	65	270.7	
	15	818	70.3	70.3	66	66	204.2	910	78.3	78.3	78	78	227.1	1099	94.5	94.5	68	68	274.3	
	40	5	583	50.2	50.2	35	35	205.3	649	55.8	55.8	41	41	228.3	784	67.4	67.4	39	39	275.7
		6	603	51.9	51.9	37	37	207.1	672	57.8	57.8	43	43	230.3	811	69.8	69.8	41	41	278.2
		7	623	53.6	53.6	39	39	208.9	694	59.7	59.7	46	46	232.3	838	72.1	72.1	44	44	280.6
		8	643	55.3	55.3	42	42	210.7	716	61.6	61.6	49	49	234.3	865	74.4	74.4	46	46	283.0
9		663	57.1	57.1	44	44	212.5	738	63.5	63.5	52	52	236.3	892	76.7	76.7	48	48	285.5	
10		683	58.8	58.8	47	47	214.4	761	65.4	65.4	55	55	238.4	919	79.0	79.0	51	51	287.9	
11		703	60.5	60.5	50	50	216.2	783	67.3	67.3	58	58	240.4	946	81.3	81.3	53	53	290.4	
12		723	62.2	62.2	52	52	218.0	805	69.2	69.2	61	61	242.4	972	83.6	83.6	56	56	292.8	
13		743	63.9	63.9	55	55	219.8	827	71.1	71.1	65	65	244.4	999	85.9	85.9	58	58	295.2	
14		763	65.7	65.7	58	58	221.6	850	73.1	73.1	68	68	246.4	1026	88.2	88.2	61	61	297.7	
15		783	67.4	67.4	61	61	223.4	872	75.0	75.0	71	71	248.5	1053	90.6	90.6	63	63	300.1	
43		5	576	49.6	49.6	34	34	222.2	641	55.2	55.2	40	40	247.0	775	66.6	66.6	38	38	298.4
		6	595	51.2	51.2	36	36	223.4	662	56.9	56.9	42	42	248.5	800	68.8	68.8	40	40	300.1
		7	614	52.8	52.8	38	38	224.7	683	58.7	58.7	45	45	249.9	825	70.9	70.9	43	43	301.8
		8	632	54.4	54.4	40	40	226.0	704	60.5	60.5	47	47	251.3	850	73.1	73.1	45	45	303.6
	9	651	56.0	56.0	43	43	227.3	724	62.3	62.3	50	50	252.7	875	75.2	75.2	47	47	305.3	
	10	670	57.6	57.6	45	45	228.6	745	64.1	64.1	53	53	254.1	900	77.4	77.4	49	49	307.0	
	11	688	59.2	59.2	48	48	229.8	766	65.9	65.9	56	56	255.6	925	79.6	79.6	51	51	308.7	
	12	707	60.8	60.8	50	50	231.1	787	67.7	67.7	59	59	257.0	950	81.7	81.7	53	53	310.4	
	13	726	62.4	62.4	53	53	232.4	807	69.4	69.4	62	62	258.4	975	83.9	83.9	56	56	312.2	
	14	744	64.0	64.0	55	55	233.7	828	71.2	71.2	65	65	259.8	1000	86.0	86.0	58	58	313.9	
	15	763	65.6	65.6	58	58	235.0	849	73.0	73.0	68	68	261.3	1025	88.2	88.2	61	61	315.6	

ABT: Condensate Air Inlet Temperature(°C)

CLOT: Chilled Water Outlet Temperature(°C)

CCAP: Cooling Capacity (kW)

CFR1,CFR2: Chilled Water Flow Rate of No.1 Unit and No.2 Unit at 5 °C Difference Between Inlet and Outlet Temperature (m³/h).

CPD1,CPD2: Water Cooler Pressure Drop of No.1 Unit and No.2 Unit (kPa)

IPT: Input Power for Unit (kW)

Conversion Multiplier: 1kW=860kcal/h
 =3412Btu/h
 1kPa=0.102mAq

ABT	COT	RCUF360AZPY1								RCUF405AZPY1							
		CCAP	CFR1	CFR2	CFR3	CPD1	CPD2	CPD3	IPT	CCAP	CFR1	CFR2	CFR3	CPD1	CPD2	CPD3	IPT
25	5	1248	71.6	71.6	71.6	43	43	43	243.5	1394	79.9	79.9	79.9	37	37	37	271.8
	6	1302	74.7	74.7	74.7	46	46	46	252.5	1454	83.3	83.3	83.3	40	40	40	281.9
	7	1356	77.7	77.7	77.7	49	49	49	261.6	1514	86.8	86.8	86.8	43	43	43	292.0
	8	1410	80.8	80.8	80.8	53	53	53	270.7	1574	90.2	90.2	90.2	46	46	46	302.2
	9	1464	83.9	83.9	83.9	56	56	56	279.7	1634	93.7	93.7	93.7	49	49	49	312.3
	10	1517	87.0	87.0	87.0	59	59	59	288.8	1694	97.1	97.1	97.1	52	52	52	322.4
	11	1571	90.1	90.1	90.1	63	63	63	297.8	1754	100.6	100.6	100.6	56	56	56	332.5
	12	1625	93.2	93.2	93.2	66	66	66	306.9	1814	104.0	104.0	104.0	59	59	59	342.6
	13	1679	96.3	96.3	96.3	70	70	70	316.0	1874	107.5	107.5	107.5	63	63	63	352.7
	14	1733	99.3	99.3	99.3	73	73	73	325.0	1934	110.9	110.9	110.9	66	66	66	362.8
15	1787	102.4	102.4	102.4	77	77	77	334.1	1994	114.3	114.3	114.3	70	70	70	373.0	
30	5	1224	70.2	70.2	70.2	42	42	42	300.2	1367	78.4	78.4	78.4	36	36	36	335.1
	6	1274	73.0	73.0	73.0	45	45	45	307.4	1422	81.5	81.5	81.5	38	38	38	343.2
	7	1323	75.9	75.9	75.9	47	47	47	314.7	1477	84.7	84.7	84.7	41	41	41	351.3
	8	1372	78.7	78.7	78.7	50	50	50	322.0	1532	87.8	87.8	87.8	44	44	44	359.4
	9	1422	81.5	81.5	81.5	53	53	53	329.2	1587	91.0	91.0	91.0	47	47	47	367.5
	10	1471	84.3	84.3	84.3	56	56	56	336.5	1642	94.1	94.1	94.1	50	50	50	375.6
	11	1520	87.2	87.2	87.2	59	59	59	343.7	1697	97.3	97.3	97.3	52	52	52	383.7
	12	1570	90.0	90.0	90.0	63	63	63	351.0	1752	100.5	100.5	100.5	56	56	56	391.8
	13	1619	92.8	92.8	92.8	66	66	66	358.3	1807	103.6	103.6	103.6	59	59	59	399.9
	14	1668	95.6	95.6	95.6	69	69	69	365.5	1862	106.8	106.8	106.8	62	62	62	408.0
15	1718	98.5	98.5	98.5	72	72	72	372.8	1917	109.9	109.9	109.9	65	65	65	416.2	
35	5	1200	68.8	68.8	68.8	40	40	40	356.9	1340	76.8	76.8	76.8	35	35	35	398.4
	6	1245	71.4	71.4	71.4	43	43	43	362.3	1390	79.7	79.7	79.7	37	37	37	404.5
	7	1290	74.0	74.0	74.0	46	46	46	367.5	1440	82.6	82.6	82.6	40	40	40	410.4
	8	1335	76.5	76.5	76.5	48	48	48	373.3	1490	85.4	85.4	85.4	42	42	42	416.7
	9	1380	79.1	79.1	79.1	51	51	51	378.7	1540	88.3	88.3	88.3	44	44	44	422.8
	10	1424	81.7	81.7	81.7	53	53	53	384.2	1590	91.2	91.2	91.2	47	47	47	428.9
	11	1469	84.2	84.2	84.2	56	56	56	389.6	1640	94.0	94.0	94.0	49	49	49	435.0
	12	1514	86.8	86.8	86.8	59	59	59	395.1	1690	96.9	96.9	96.9	52	52	52	441.1
	13	1559	89.4	89.4	89.4	62	62	62	400.6	1740	99.8	99.8	99.8	55	55	55	447.2
	14	1604	91.9	91.9	91.9	65	65	65	406.0	1790	102.6	102.6	102.6	58	58	58	453.3
15	1649	94.5	94.5	94.5	68	68	68	411.5	1840	105.5	105.5	105.5	61	61	61	459.4	
40	5	1176	67.4	67.4	67.4	39	39	39	413.6	1313	75.3	75.3	75.3	33	33	33	461.7
	6	1217	69.8	69.8	69.8	41	41	41	417.2	1358	77.9	77.9	77.9	35	35	35	465.8
	7	1257	72.1	72.1	72.1	44	44	44	420.9	1403	80.4	80.4	80.4	37	37	37	469.9
	8	1297	74.4	74.4	74.4	46	46	46	424.6	1448	83.0	83.0	83.0	40	40	40	474.0
	9	1338	76.7	76.7	76.7	48	48	48	428.2	1493	85.6	85.6	85.6	42	42	42	478.0
	10	1378	79.0	79.0	79.0	51	51	51	431.9	1538	88.2	88.2	88.2	44	44	44	482.1
	11	1418	81.3	81.3	81.3	53	53	53	435.5	1583	90.8	90.8	90.8	46	46	46	486.2
	12	1459	83.6	83.6	83.6	56	56	56	439.2	1628	93.4	93.4	93.4	49	49	49	490.3
	13	1499	85.9	85.9	85.9	58	58	58	442.9	1673	95.9	95.9	95.9	51	51	51	494.4
	14	1539	88.2	88.2	88.2	61	61	61	446.5	1718	98.5	98.5	98.5	54	54	54	498.5
15	1580	90.6	90.6	90.6	63	63	63	450.2	1763	101.1	101.1	101.1	56	56	56	502.6	
43	5	1162	66.6	66.6	66.6	38	38	38	447.6	1297	74.4	74.4	74.4	33	33	33	499.7
	6	1200	68.8	68.8	68.8	40	40	40	450.2	1339	76.8	76.8	76.8	35	35	35	502.6
	7	1237	70.9	70.9	70.9	43	43	43	452.8	1381	79.2	79.2	79.2	36	36	36	505.4
	8	1275	73.1	73.1	73.1	45	45	45	455.3	1423	81.6	81.6	81.6	38	38	38	508.3
	9	1312	75.2	75.2	75.2	47	47	47	457.9	1465	84.0	84.0	84.0	40	40	40	511.2
	10	1350	77.4	77.4	77.4	49	49	49	460.5	1507	86.4	86.4	86.4	43	43	43	514.1
	11	1388	79.6	79.6	79.6	51	51	51	463.1	1549	88.8	88.8	88.8	45	45	45	517.0
	12	1425	81.7	81.7	81.7	53	53	53	465.7	1591	91.2	91.2	91.2	47	47	47	519.8
	13	1463	83.9	83.9	83.9	56	56	56	468.2	1633	93.6	93.6	93.6	49	49	49	522.7
	14	1501	86.0	86.0	86.0	58	58	58	470.8	1675	96.0	96.0	96.0	51	51	51	525.6
15	1538	88.2	88.2	88.2	61	61	61	473.4	1717	98.4	98.4	98.4	54	54	54	528.5	

ABT: Condensate Air Inlet Temperature (°C)

CLOT: Chilled Water Outlet Temperature (°C)

CCAP: Cooling Capacity (kW)

CFR1,CFR2,CFR3: Chilled Water Flow Rate of No.1 Unit No.2 Unit and No.3 Unit at 5 °C difference Between Inlet and Outlet Temperature (m³/h)

CPD1,CPD2,CPD3: Water Cooler Pressure Drop of No.1 Unit No.2 Unit and No.3 Unit (kPa)

IPT: Input Power for Unit (kW)

Conversion Multiplier: 1kW=860kcal/h
 =3412Btu/h
 1kPa=0.102mAq

ABT	COT	RCUF420AZPY1								RCUF450AZPY1								
		CCAP	CFR1	CFR2	CFR3	CPD1	CPD2	CPD3	IPT	CCAP	CFR1	CFR2	CFR3	CPD1	CPD2	CPD3	IPT	
25	5	1446	88.9	79.9	79.9	45	37	37	282.0	1550	88.9	88.9	88.9	45	45	45	302.4	
	6	1508	92.7	83.3	83.3	48	40	40	292.5	1617	92.7	92.7	92.7	48	48	48	313.7	
	7	1570	96.5	86.8	86.8	52	43	43	303.0	1684	96.5	96.5	96.5	52	52	52	324.9	
	8	1633	100.4	90.2	90.2	55	46	46	313.5	1751	100.4	100.4	100.4	55	55	55	336.2	
	9	1695	104.2	93.7	93.7	59	49	49	324.0	1818	104.2	104.2	104.2	59	59	59	347.5	
	10	1757	108.0	97.1	97.1	63	52	52	334.5	1884	108.0	108.0	108.0	63	63	63	358.7	
	11	1820	111.9	100.6	100.6	67	56	56	345.0	1951	111.9	111.9	111.9	67	67	67	370.0	
	12	1882	115.7	104.0	104.0	71	59	59	355.5	2018	115.7	115.7	115.7	71	71	71	381.2	
	13	1944	119.5	107.5	107.5	76	63	63	366.0	2085	119.5	119.5	119.5	76	76	76	392.5	
	14	2007	123.4	110.9	110.9	80	66	66	376.5	2152	123.4	123.4	123.4	80	80	80	403.7	
	15	2069	127.2	114.3	114.3	84	70	70	387.0	2219	127.2	127.2	127.2	84	84	84	415.0	
	30	5	1418	87.2	78.4	78.4	43	36	36	347.7	1520	87.2	87.2	87.2	43	43	43	372.9
		6	1475	90.7	81.5	81.5	46	38	38	356.1	1582	90.7	90.7	90.7	46	46	46	381.9
		7	1532	94.2	84.7	84.7	50	41	41	364.5	1643	94.2	94.2	94.2	50	50	50	390.9
		8	1589	97.7	87.8	87.8	53	44	44	372.9	1704	97.7	97.7	97.7	53	53	53	399.9
9		1646	101.2	91.0	91.0	56	47	47	381.3	1765	101.2	101.2	101.2	56	56	56	408.9	
10		1704	104.7	94.1	94.1	60	50	50	389.7	1827	104.7	104.7	104.7	60	60	60	418.0	
11		1761	108.2	97.3	97.3	63	52	52	398.1	1888	108.2	108.2	108.2	63	63	63	427.0	
12		1818	111.8	100.5	100.5	67	56	56	406.6	1949	111.8	111.8	111.8	67	67	67	436.0	
13		1875	115.3	103.6	103.6	71	59	59	415.0	2010	115.3	115.3	115.3	71	71	71	445.0	
14		1932	118.8	106.8	106.8	75	62	62	423.4	2072	118.8	118.8	118.8	75	75	75	454.0	
15		1989	122.3	109.9	109.9	79	65	65	431.8	2133	122.3	122.3	122.3	79	79	79	463.0	
5		1390	85.5	76.8	76.8	42	35	35	413.4	1491	85.5	85.5	85.5	42	42	42	443.3	
6		1442	88.7	79.7	79.7	45	37	37	419.7	1546	88.7	88.7	88.7	45	45	45	450.1	
7		1494	91.8	82.6	82.6	46	40	40	425.7	1602	91.8	91.8	91.8	46	46	46	456.3	
8		1546	95.0	85.4	85.4	50	42	42	432.3	1658	95.0	95.0	95.0	50	50	50	463.6	
9	1598	98.2	88.3	88.3	53	44	44	438.7	1713	98.2	98.2	98.2	53	53	53	470.4		
10	1650	101.4	91.2	91.2	56	47	47	445.0	1769	101.4	101.4	101.4	56	56	56	477.2		
11	1702	104.6	94.0	94.0	60	49	49	451.3	1825	104.6	104.6	104.6	60	60	60	484.0		
12	1754	107.8	96.9	96.9	63	52	52	457.6	1880	107.8	107.8	107.8	63	63	63	490.8		
13	1805	111.0	99.8	99.8	66	55	55	464.0	1936	111.0	111.0	111.0	66	66	66	497.6		
14	1857	114.2	102.6	102.6	70	58	58	470.3	1992	114.2	114.2	114.2	70	70	70	504.3		
15	1909	117.4	105.5	105.5	73	61	61	476.6	2047	117.4	117.4	117.4	73	73	73	511.1		
40	5	1362	83.8	75.3	75.3	40	33	33	479.0	1461	83.8	83.8	83.8	40	40	40	513.7	
	6	1409	86.6	77.9	77.9	43	35	35	483.3	1511	86.6	86.6	86.6	43	43	43	518.3	
	7	1456	89.5	80.4	80.4	45	37	37	487.5	1561	89.5	89.5	89.5	45	45	45	522.8	
	8	1502	92.4	83.0	83.0	48	40	40	491.8	1611	92.4	92.4	92.4	48	48	48	527.4	
	9	1549	95.2	85.6	85.6	51	42	42	496.0	1661	95.2	95.2	95.2	51	51	51	531.9	
	10	1596	98.1	88.2	88.2	53	44	44	500.2	1711	98.1	98.1	98.1	53	53	53	536.5	
	11	1643	101.0	90.8	90.8	56	46	46	504.5	1761	101.0	101.0	101.0	56	56	56	541.0	
	12	1689	103.9	93.4	93.4	59	49	49	508.7	1811	103.9	103.9	103.9	59	59	59	545.6	
	13	1736	106.7	95.9	95.9	62	51	51	513.0	1861	106.7	106.7	106.7	62	62	62	550.1	
	14	1783	109.6	98.5	98.5	65	54	54	517.2	1912	109.6	109.6	109.6	65	65	65	554.6	
	15	1829	112.5	101.1	101.1	68	56	56	521.4	1962	112.5	112.5	112.5	68	68	68	559.2	
	5	1346	82.7	74.4	74.4	39	33	33	518.4	1443	82.7	82.7	82.7	39	39	39	556.0	
	6	1389	85.4	76.8	76.8	42	35	35	521.4	1490	85.4	85.4	85.4	42	42	42	559.2	
	7	1433	88.1	79.2	79.2	44	36	36	524.4	1536	88.1	88.1	88.1	44	44	44	562.4	
	8	1476	90.8	81.6	81.6	46	38	38	527.4	1583	90.8	90.8	90.8	46	46	46	565.6	
9	1520	93.4	84.0	84.0	49	40	40	530.4	1630	93.4	93.4	93.4	49	49	49	568.8		
10	1564	96.1	86.4	86.4	51	43	43	533.4	1677	96.1	96.1	96.1	51	51	51	572.0		
11	1607	98.8	88.8	88.8	54	45	45	536.4	1723	98.8	98.8	98.8	54	54	54	575.2		
12	1651	101.5	91.2	91.2	57	47	47	539.4	1770	101.5	101.5	101.5	57	57	57	578.4		
13	1694	104.2	93.6	93.6	59	49	49	542.4	1817	104.2	104.2	104.2	59	59	59	581.6		
14	1738	106.8	96.0	96.0	62	51	51	545.3	1863	106.8	106.8	106.8	62	62	62	584.8		
15	1781	109.5	98.4	98.4	65	54	54	548.3	1910	109.5	109.5	109.5	65	65	65	588.0		

ABT: Condensate Air Inlet Temperature (°C) CLOT: Chilled Water Outlet Temperature (°C)
 CCAP: Cooling Capacity (kW)
 CFR1,CFR2,CFR3: Chilled Water Flow Rate of No.1 Unit No.2 Unit and No.3 Unit at 5 °C iffrence Between Inlet and Outlet Temperature (m³/h).
 CPD1,CPD2,CPD3: Water Cooler Pressure Drop of No.1 Unit No.2 Unit and No.3 Unit (kPa)
 IPT: Input Power for Unit (kW)

10. Electrical Data

(Voltage:380V)

Model	Unit Main Power		Application Voltage (V)		Compressor(Three Phases)			Motor for Condenser Fan		Maximum Unit Current(A)
	Voltage	Hz	Max.	Min.	STC (A)	RNC(A)	IPT (kW)	RNC(A)	IPT (kW)	
RCUF45AZY1	380	50	418	342	211	84	44.1	4x2.7	4x1.1	142
RCUF50AZY1					211	94	49.3	4x2.7	4x1.1	157
RCUF60AZY1					211	110	61.6	4x2.7	4x1.1	181
RCUF90AZY1					211	2x84	2x44.1	8x2.7	8x1.1	283
RCUF100AZY1					211	2x94	2x49.3	8x2.7	8x1.1	313
RCUF120AZY1					211	2x113	2x61.6	8x2.7	8x1.1	362
RCUF150AZY1					211	3x95	3x49.3	12x2.7	12x1.1	470
RCUF180AZY1					211	3x110	3x61.6	12x2.7	12x1.1	544
RCUF200AZY1					211	4x94	4x49.3	16x2.7	16x1.1	626
RCUF220AZY1					211	2x113+2x94	2x61.6+2x49.3	16x2.7	16x1.1	675
RCUF240AZY1					211	4x113	4x61.6	16x2.7	16x1.1	724
RCUF270AZY1					211	3x95+2x113	3x49.3+2x61.6	20x2.7	20x1.1	832
RCUF300AZY1					211	6x95	6x49.3	24x2.7	24x1.1	940
RCUF330AZY1					211	3x110+3x95	3x61.6+3x49.3	24x2.7	24x1.1	1014
RCUF360AZY1					211	6x110	6x61.6	24x2.7	24x1.1	1088
RCUF400AZY1					211	6x95+2x94	6x49.3+2x49.3	32x2.7	32x1.1	1253
RCUF420AZY1					211	6x95+2x113	6x49.3+2x61.6	32x2.7	32x1.1	1302
RCUF450AZY1					211	9x95	9x49.3	36x2.7	36x1.1	1410
RCUF45AZPY1					211	78	41.2	4x2.7	4x1.1	134
RCUF50AZPY1					211	88	46.3	4x2.7	4x1.1	148
RCUF60AZPY1					211	98	54.7	6x2.7	6x1.1	171
RCUF90AZPY1					211	2x78	2x41.2	8x2.7	8x1.1	267
RCUF100AZPY1					211	2x88	2x46.3	8x2.7	8x1.1	296
RCUF120AZPY1					211	2x98	2x54.7	12x2.7	12x1.1	342
RCUF135AZPY1					211	3x78	3x41.2	12x2.7	12x1.1	401
RCUF150AZPY1					211	3x88	3x46.3	12x2.7	12x1.1	444
RCUF180AZPY1					211	4x78	4x41.2	16x2.7	16x1.1	536
RCUF200AZPY1					211	4x88	4x46.3	16x2.7	16x1.1	592
RCUF240AZPY1					211	4x98	4x54.7	24x2.7	24x1.1	684
RCUF270AZPY1					211	6x78	6x41.2	24x2.7	24x1.1	786
RCUF300AZPY1					211	6x88	6x46.3	24x2.7	24x1.1	888
RCUF320AZPY1					211	4x88+2x98	4x46.3+2x54.7	28x2.7	28x1.1	934
RCUF360AZPY1	211	6x98	6x54.7	36x2.7	36x1.1	1072				
RCUF405AZPY1	211	9x78	9x41.2	36x2.7	36x1.1	1203				
RCUF420AZPY1	211	6x88+2x98	6x46.3+2x54.7	36x2.7	36x1.1	1230				
RCUF450AZPY1	211	9x88	9x46.3	36x2.7	36x1.1	1332				

RNC: Running Current IPT: Power Input

- These data are based on the same conditions as those for the cooling capacity; please refer to the notes for the Unit General Data.
- The starting current is indicated for each compressor.
- The "Maximum Unit Current" is the total running current of the unit under the following conditions, which consume the maximum current within the unit working range.

Supplied Voltage: Rated Voltage×0.9
 Condenser Air Inlet Temperature: 43 °C
 Chilled Water Outlet Temperature: 15 °C
 Capacity Control: 100%

Therefore, the size of wiring and fuses must be determined according to applicable national and local codes.

- In addition to the conditions mentioned in the item 3, the compressor currents can be estimated as shown below.

	One-Compressor
Maximum Instantaneous Current	STC

- The unit power input can be estimated from that of the compressor in the Cooling Capacity Table and that of the condenser fan motor above.

(Voltage:415V)

Model	Unit Main Power		Application Voltage (V)		Compressor(Three Phases)			Motor for Condenser Fan		Maximum Unit Current(A)
	Voltage	Hz	Max.	Min.	STC (A)	RNC(A)	IPT (kW)	RNC(A)	IPT (kW)	
RCUF45AZY1	415	50	456	374	230	77	44.1	4x2.7	4x1.1	131
RCUF50AZY1					230	86	49.3	4x2.7	4x1.1	145
RCUF60AZY1					230	101	61.6	4x2.7	4x1.1	167
RCUF90AZY1					230	2x77	2x44.1	8x2.7	8x1.1	262
RCUF100AZY1					230	2x86	2x49.3	8x2.7	8x1.1	290
RCUF120AZY1					230	2x103	2x61.6	8x2.7	8x1.1	335
RCUF150AZY1					230	3x87	3x49.3	12x2.7	12x1.1	434
RCUF180AZY1					230	3x101	3x61.6	12x2.7	12x1.1	502
RCUF200AZY1					230	4x86	4x49.3	16x2.7	16x1.1	580
RCUF220AZY1					230	2x103+2x86	2x61.6+2x49.3	16x2.7	16x1.1	625
RCUF240AZY1					230	4x103	4x61.6	16x2.7	16x1.1	670
RCUF270AZY1					230	3x87+2x103	3x49.3+2x61.6	20x2.7	20x1.1	769
RCUF300AZY1					230	6x87	6x49.3	24x2.7	24x1.1	868
RCUF330AZY1					230	3x101+3x87	3x61.6+3x49.3	24x2.7	24x1.1	936
RCUF360AZY1					230	6x101	6x61.6	24x2.7	24x1.1	1004
RCUF400AZY1					230	6x87+2x86	6x49.3+2x49.3	32x2.7	32x1.1	1158
RCUF420AZY1					230	6x87+2x103	6x49.3+2x61.6	32x2.7	32x1.1	1203
RCUF450AZY1					230	9x87	9x49.3	36x2.7	36x1.1	1302
RCUF45AZPY1					230	72	41.2	4x2.7	4x1.1	124
RCUF50AZPY1					230	81	46.3	4x2.7	4x1.1	137
RCUF60AZPY1					230	89	54.7	6x2.7	6x1.1	159
RCUF90AZPY1					230	2x72	2x41.2	8x2.7	8x1.1	247
RCUF100AZPY1					230	2x81	2x46.3	8x2.7	8x1.1	274
RCUF120AZPY1					230	2x89	2x54.7	12x2.7	12x1.1	317
RCUF135AZPY1					230	3x72	3x41.2	12x2.7	12x1.1	371
RCUF150AZPY1					230	3x81	3x46.3	12x2.7	12x1.1	411
RCUF180AZPY1					230	4x72	4x41.2	16x2.7	16x1.1	494
RCUF200AZPY1					230	4x81	4x46.3	16x2.7	16x1.1	548
RCUF240AZPY1					230	4x89	4x54.7	24x2.7	24x1.1	634
RCUF270AZPY1					230	6x72	6x41.2	24x2.7	24x1.1	742
RCUF300AZPY1					230	6x81	6x46.3	24x2.7	24x1.1	822
RCUF320AZPY1					230	4x81+2x89	4x46.3+2x54.7	28x2.7	28x1.1	865
RCUF360AZPY1					230	6x89	6x54.7	36x2.7	36x1.1	951
RCUF405AZPY1					230	9x72	9x41.2	36x2.7	36x1.1	1113
RCUF420AZPY1					230	6x81+2x89	6x46.3+2x54.7	36x2.7	36x1.1	1153
RCUF450AZPY1					230	9x81	9x46.3	36x2.7	36x1.1	1233

RNC: Running Current IPT: Power Input

1. These data are based on the same conditions as those for the cooling capacity; please refer to the notes for the Unit General Data.
2. The starting current is indicated for each compressor.
3. The "Maximum Unit Current" is the total running current of the unit under the following conditions, which consume the maximum current within the unit working range.

Supplied Voltage: Rated Voltage \times 0.9

Condenser Air Inlet Temperature: 43 °C

Chilled Water Outlet Temperature: 15 °C

Capacity Control: 100%

Therefore, the size of wiring and fuses must be determined according to applicable national and local codes.

4. In addition to the conditions mentioned in the item 3, the compressor currents can be estimated as shown below.

	One-Compressor
Maximum Instantaneous Current	STC

5. The unit power input can be estimated from that of the compressor in the Cooling Capacity Table and that of the condenser fan motor above.

11. Sound Data

Model	Sound Data (dB)	Model	Sound Data (dB)
RCUF45AZY1	78	RCUF45AZPY1	78
RCUF50AZY1	78	RCUF50AZPY1	78
RCUF60AZY1	78	RCUF60AZPY1	78
RCUF90AZY1	81	RCUF90AZPY1	81
RCUF100AZY1	81	RCUF100AZPY1	81
RCUF120AZY1	81	RCUF120AZPY1	81
RCUF150AZY1	83	RCUF135AZPY1	83
RCUF180AZY1	83	RCUF150AZPY1	83
RCUF200AZY1	84	RCUF180AZPY1	84
RCUF220AZY1	84	RCUF200AZPY1	84
RCUF240AZY1	84	RCUF240AZPY1	84
RCUF270AZY1	85	RCUF270AZPY1	86
RCUF300AZY1	86	RCUF300AZPY1	86
RCUF330AZY1	86	RCUF320AZPY1	86
RCUF360AZY1	86	RCUF360AZPY1	86
RCUF400AZY1	87	RCUF405AZPY1	87.5
RCUF420AZY1	87	RCUF420AZPY1	87.5
RCUF450AZY1	87.5	RCUF450AZPY1	87.5

Notes:

- (1) Sound Data in accordance with JB/T4330.
- (2) Based on the actual state of installation, operation, the influence of ambient noise and echo, lead to actual noise value is higher than the specification (vary according to the state, also have higher about 4 ~ 6 db).
- (3) Should avoid installation to those who are not allowed and the position of the exhaust noise. Such as the need to install the noise sensitive position, need to advance design and installation of the acoustical isolation facilities, to keep the unit running the noise impact on the surrounding environment under control.

12. Working Range

Power Supply:

Working Voltage : 90%-100% Rating Voltage

Unbalanced Voltage : Within $\pm 3\%$ Deviation from Each Voltage at Compressor Terminals

Start Voltage: Higher than 90% of the Rated Voltage

Maximum Water Flow Rate and Minimum Water Flow Rate (m³/h)

Model	Max.Flow Rate	Min.Flow Rate	Model	Max.Flow Rate	Min.Flow Rate
RCUF45AZY1	38.9	13.6	RCUF45AZPY1	39.4	13.8
RCUF50AZY1	43.1	15.1	RCUF50AZPY1	43.8	15.3
RCUF60AZY1	52.9	18.5	RCUF60AZPY1	52.9	18.5
RCUF90AZY1	77.8	27.2	RCUF90AZPY1	78.7	27.5
RCUF100AZY1	86.1	30.1	RCUF100AZPY1	87.6	30.6
RCUF120AZY1	105.8	37.0	RCUF120AZPY1	105.8	37.0
RCUF150AZY1	129.2	45.2	RCUF135AZPY1	118.1	41.3
RCUF180AZY1	158.7	55.5	RCUF150AZPY1	131.4	45.9
RCUF200AZY1	86.1/86.1	30.1/30.1	RCUF180AZPY1	78.7/78.7	27.5/27.5
RCUF220AZY1	105.8/86.1	37/30.1	RCUF200AZPY1	87.6/87.6	30.6/30.6
RCUF240AZY1	105.8/105.8	37/37	RCUF240AZPY1	105.8/105.8	37/37
RCUF270AZY1	129.2/105.8	45.2/37	RCUF270AZPY1	118.1/118.1	41.3/41.3
RCUF300AZY1	129.2/129.2	45.2/45.2	RCUF300AZPY1	131.4/131.4	45.9/45.9
RCUF330AZY1	158.8/129.2	55.5/45.2	RCUF320AZPY1	87.6/87.6/105.8	30.6/30.6/37
RCUF360AZY1	158.7/158.7	55.5/55.5	RCUF360AZPY1	105.8/105.8/105.8	37/37/37
RCUF400AZY1	129.2/129.2/86.1	45.2/45.2/30.1	RCUF405AZPY1	118.1/118.1/118.1	41.3/41.3/41.3
RCUF420AZY1	129.2/129.2/105.8	45.2/45.2/37	RCUF420AZPY1	131.4/118.1/118.1	45.9/41.3/41.3
RCUF450AZY1	129.2/129.2/129.2	45.2/45.2/45.2	RCUF450AZPY1	131.4/131.4/131.4	45.9/45.9/45.9

Internal Water Volume in Water Cooler (m³)

Model	Volume	Model	Volume
RCUF45AZY1	0.073	RCUF45AZPY1	0.091
RCUF50AZY1	0.073	RCUF50AZPY1	0.091
RCUF60AZY1	0.091	RCUF60AZPY1	0.123
RCUF90AZY1	0.201	RCUF90AZPY1	0.187
RCUF100AZY1	0.201	RCUF100AZPY1	0.187
RCUF120AZY1	0.187	RCUF120AZPY1	0.223
RCUF150AZY1	0.238	RCUF135AZPY1	0.273
RCUF180AZY1	0.273	RCUF150AZPY1	0.273
RCUF200AZY1	0.201/0.201	RCUF180AZPY1	0.187/0.187
RCUF220AZY1	0.187/0.201	RCUF200AZPY1	0.187/0.187
RCUF240AZY1	0.187/0.187	RCUF240AZPY1	0.223/0.223
RCUF270AZY1	0.238/0.187	RCUF270AZPY1	0.273/0.273
RCUF300AZY1	0.238/0.238	RCUF300AZPY1	0.273/0.273
RCUF330AZY1	0.273/0.238	RCUF320AZPY1	0.187/0.187/0.223
RCUF360AZY1	0.273/0.273	RCUF360AZPY1	0.223/0.223/0.223
RCUF400AZY1	0.238/0.238/0.201	RCUF405AZPY1	0.273/0.273/0.273
RCUF420AZY1	0.238/0.238/0.187	RCUF420AZPY1	0.273/0.273/0.273
RCUF450AZY1	0.238/0.238/0.238	RCUF450AZPY1	0.273/0.273/0.273

Minimum Internal System Water Volume

Model	Volume (m ³)	Model	Volume (m ³)
RCUF45AZY1	0.57	RCUF45AZPY1	0.58
RCUF50AZY1	0.63	RCUF50AZPY1	0.64
RCUF60AZY1	0.78	RCUF60AZPY1	0.78
RCUF90AZY1	1.14	RCUF90AZPY1	1.16
RCUF100AZY1	1.27	RCUF100AZPY1	1.29
RCUF120AZY1	1.55	RCUF120AZPY1	1.55
RCUF150AZY1	1.9	RCUF135AZPY1	1.74
RCUF180AZY1	2.33	RCUF150AZPY1	1.93
RCUF200AZY1	2.53	RCUF180AZPY1	2.31
RCUF220AZY1	2.82	RCUF200AZPY1	2.57
RCUF240AZY1	3.11	RCUF240AZPY1	3.11
RCUF270AZY1	3.45	RCUF270AZPY1	3.47
RCUF300AZY1	3.8	RCUF300AZPY1	3.86
RCUF330AZY1	4.23	RCUF320AZPY1	4.13
RCUF360AZY1	4.66	RCUF360AZPY1	4.66
RCUF400AZY1	5.06	RCUF405AZPY1	5.21
RCUF420AZY1	5.35	RCUF420AZPY1	5.4
RCUF450AZY1	5.69	RCUF450AZPY1	5.79

Note: Minimum internal system water volume in the above table is setting according to the standard neutral zone temperature. In case of changing the setting, minimum internal system water volume shall be increased as follows.

Water Neutral Zone Temperature	Minimum Water Volume in System
2°C (Standard)	100%
1.5 °C	130%
1 °C	200%

Temperature Range

The temperature range is given in the following table.

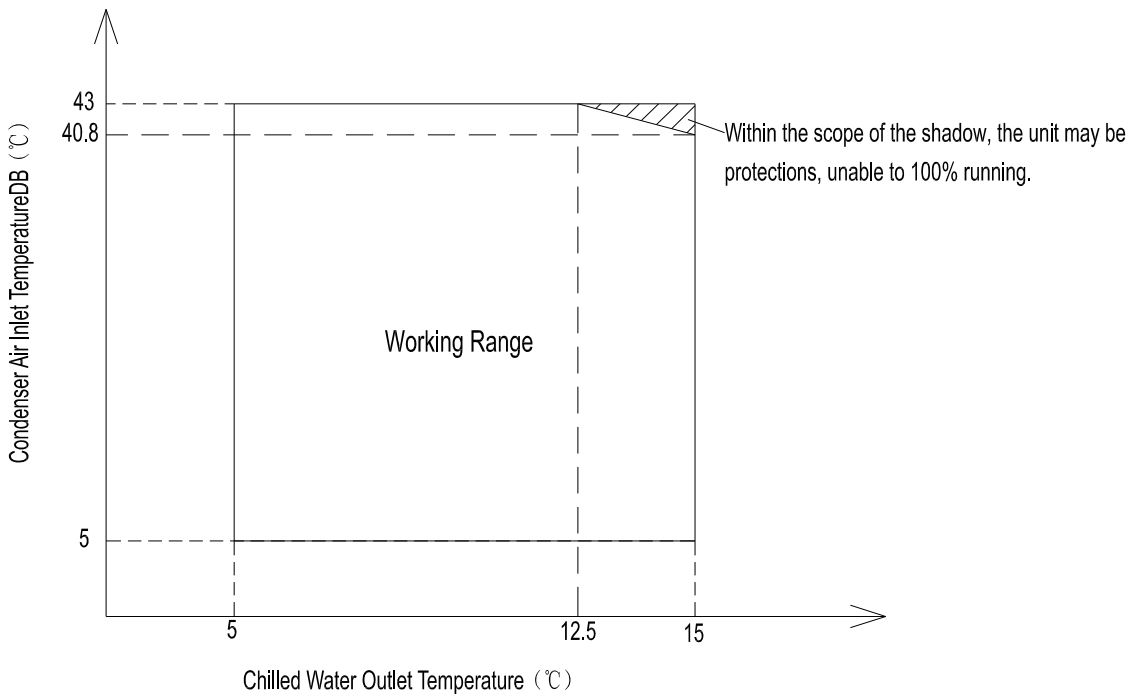

13. Component Detailed Data

Compressor

Model of compressor			ASCCW-50ZG	ASCCW-60ZG
Type of compressor		—	Semi-hermetic	
Quantity of rotors		Pair	1	1
Displacement		m ³ /h	272	340
Control of cooling capacity	Continuous control	%	100~25,0	100~25,0
Proof Pressure	Discharge & suction	MPa	3.1	3.1
Pressure of airtight	Discharge & suction	MPa	2.02	2.02
Motor	Type	—	three-phase asynchronous motor	
	Starting method	—	star delta starting	
	Number of poles	—	2	
	Insulation grade	—	F	
	Power	kW	37	45
Lubricating oil	Model	—	ZE-GLES RB68	
	Oil volume	L	6	6

Condenser and Condenser Fan

Model		RCUF45 AZY1	RCUF50 AZY1	RCUF60 AZY1	RCUF90 AZY1	RCUF100 AZY1	RCUF120 AZY1	RCUF150 AZY1	RCUF180 AZY1	RCUF200 AZY1	
Condenser Type		Multi-Pass Cross Finned Tube									
Condenser Piping	Material	Copper Tube									
	Outer Diameter	mm	7	7	7	7	7	7	7	7	
	Tube Thickness(mean)	mm	0.27	0.27	0.27	0.27	0.27	0.27	0.27	0.27	
Fin Material		Aluminum									
Maximum Operation Pressure		MPa	2.02	2.02	2.02	2.02	2.02	2.02	2.02	2.02	
Number of Condenser/unit(s)		—	4	4	4	8	8	12	12	16	
Condenser Fan	Type	Direct-Drive Propeller Fan									
	Number/Unit	—	4	4	4	8	8	8	12	12	16
	Outer Diameter	mm	710	710	710	710	710	710	710	710	710
	Revolution	r/min	960	960	960	960	960	960	960	960	960
Condenser Fan Motor	Type	Drip-Proof Enclosure									
	Starting Method	Direct-On-Line Starting									
	Nominal Output	kW	0.9	0.9	0.9	0.9	0.9	0.9	0.9	0.9	0.9
	Quantity	—	4	4	4	8	8	8	12	12	16
	Insulation Class	—	E	E	E	E	E	E	E	E	E
	Poles	—	6	6	6	6	6	6	6	6	6
Model		RCUF220 AZY1	RCUF240 AZY1	RCUF270 AZY1	RCUF300 AZY1	RCUF330 AZY1	RCUF360 AZY1	RCUF400 AZY1	RCUF420 AZY1	RCUF450 AZY1	
Condenser Type		Multi-Pass Cross Finned Tube									
Condenser Piping	Material	Copper Tube									
	Outer Diameter	mm	7	7	7	7	7	7	7	7	
	Tube Thickness(mean)	mm	0.27	0.27	0.27	0.27	0.27	0.27	0.27	0.27	
Fin Material		Aluminum									
Maximum Operation Pressure		MPa	2.02	2.02	2.02	2.02	2.02	2.02	2.02	2.02	
Number of Condenser/unit(s)		—	16	16	20	24	24	24	32	32	36
Condenser Fan	Type	Direct-Drive Propeller Fan									
	Number/Unit	—	16	16	20	24	24	24	32	32	36
	Outer Diameter	mm	710	710	710	710	710	710	710	710	710
	Revolution	r/min	960	960	960	960	960	960	960	960	960
Condenser Fan Motor	Type	Drip-Proof Enclosure									
	Starting Method	Direct-On-Line Starting									
	Nominal Output	kW	0.9	0.9	0.9	0.9	0.9	0.9	0.9	0.9	0.9
	Quantity	—	16	16	20	24	24	24	32	32	36
	Insulation Class	—	E	E	E	E	E	E	E	E	E
	Poles	—	6	6	6	6	6	6	6	6	6

Model		RCUF45 AZY1	RCUF50 AZY1	RCUF60 AZY1	RCUF90 AZY1	RCUF100 AZY1	RCUF120 AZY1	RCUF135 AZY1	RCUF150 AZY1	RCUF180 AZY1	
Condenser Type		Multi-Pass Cross Finned Tube									
Condenser Piping	Material	Copper Tube									
	Outer Diameter	mm	7	7	7	7	7	7	7	7	7
	Tube Thickness(mean)	mm	0.27	0.27	0.27	0.27	0.27	0.27	0.27	0.27	0.27
	Fin Material	Aluminum									
Maximum Operation Pressure	MPa	2.02	2.02	2.02	2.02	2.02	2.02	2.02	2.02	2.02	
Number of Condenser/unit(s)	—	4	4	4	8	8	8	12	12	16	
Condenser Fan	Type	Direct-Drive Propeller Fan									
	Number/Unit	—	4	4	6	8	8	12	12	12	16
	Outer Diameter	mm	710	710	710	710	710	710	710	710	710
	Revolution	r/min	960	960	960	960	960	960	960	960	960
Condenser Fan Motor	Type	Drip-Proof Enclosure									
	Starting Method	Direct-On-Line Starting									
	Nominal Output	kW	0.9	0.9	0.9	0.9	0.9	0.9	0.9	0.9	0.9
	Quantity	—	4	4	6	8	8	12	12	12	16
	Insulation Class	—	E	E	E	E	E	E	E	E	E
	Poles	—	6	6	6	6	6	6	6	6	6
Model		RCUF200 AZY1	RCUF240 AZY1	RCUF270 AZY1	RCUF300 AZY1	RCUF320 AZY1	RCUF360 AZY1	RCUF405 AZY1	RCUF420 AZY1	RCUF450 AZY1	
Condenser Type		Multi-Pass Cross Finned Tube									
Condenser Piping	Material	Copper Tube									
	Outer Diameter	mm	7	7	7	7	7	7	7	7	7
	Tube Thickness(mean)	mm	0.27	0.27	0.27	0.27	0.27	0.27	0.27	0.27	0.27
Fin Material	Aluminum										
Maximum Operation Pressure	MPa	2.02	2.02	2.02	2.02	2.02	2.02	2.02	2.02	2.02	
Number of Condenser/unit(s)	—	16	16	24	24	24	24	36	36	36	
Condenser Fan	Type	Direct-Drive Propeller Fan									
	Number/Unit	—	16	24	24	24	28	36	36	36	36
	Outer Diameter	mm	710	710	710	710	710	710	710	710	710
	Revolution	r/min	960	960	960	960	960	960	960	960	960
Condenser Fan Motor	Type	Drip-Proof Enclosure									
	Starting Method	Direct-On-Line Starting									
	Nominal Output	kW	0.9	0.9	0.9	0.9	0.9	0.9	0.9	0.9	0.9
	Quantity	—	16	24	24	24	28	36	36	36	36
	Insulation Class	—	E	E	E	E	E	E	E	E	E
	Poles	—	6	6	6	6	6	6	6	6	6

Water Cooler

Model		RCUF45 AZY1	RCUF50 AZY1	RCUF60 AZY1	RCUF90 AZY1	RCUF100 AZY1	RCUF120 AZY1	RCUF150 AZY1	RCUF180 AZY1	RCUF200 AZY1		
Shell	Water Side	Shell Material	Steel									
		Outer Diameter	mm	356	356	392	394	394	394	441	482	394
		Length	mm	1,286	1,286	1,278	2,540	2,540	2,540	2,532	2,532	2,540
	Refrigerant Side	Shell Material	Steel									
		Outer Diameter	mm	362	362	412	412	412	412	462	512	412
		Length	mm	107	107	117	117	117	117	120	136	117
	Thickness	mm	6	6	6	6	6	6	6	6		
Tube	Material	Copper										
	Outer Diameter	mm	12.7	12.7	12.7	12.7	12.7	12.7	12.7	12.7	12.7	
	Quantity(No.1/No.2)	—	297	297	345	294	294	338	415	536	294/294	
Number of Pass	—	4	4	4	2	2	2	2	2	2/2		
Maximum Permissible Pressure	Refrigerant Side	MPa	1.02	1.02	1.02	1.02	1.02	1.02	1.02	1.02		
	Water Side	MPa	1.0	1.0	1.0	1.0	1.0	1.0	1.0	1.0		
Insulation		Polyethylene (19mm)										

Model			RCUF220 AZY1	RCUF240 AZY1	RCUF270 AZY1	RCUF300 AZY1	RCUF330 AZY1	RCUF360 AZY1	RCUF400 AZY1	RCUF420 AZY1	RCUF450 AZY1	
Shell	Water Side	Shell Material	Steel									
		Outer Diameter	mm	394	394	441/394	441	482/441	482	441/394	441/394	441
		Length	mm	2,540	2,540	2532/2540	2,532	2,532	2,532	2532/2540	2532/2540	2,532
	Refrigerant Side	Shell Material	Steel									
		Outer Diameter	mm	412	412	462/412	462	512/462	512	462/412	462/412	462
		Length	mm	117	117	120/117	120	136/120	136	120/117	120/117	120
	Thickness	mm	6	6	6	6	6	6	6	6	6	
Tube	Material	Copper										
	Outer Diameter	mm	12.7	12.7	12.7	12.7	12.7	12.7	12.7	12.7	12.7	
	Quantity(No.1/No.2/No.3)	—	338/294	338/338	415/338	415/415	536/415	536/536	415/415/294	415/415/338	415/415/415	
	Number of Pass	—	2/2	2/2	2/2	2/2	2/2	2/2	2/2/2	2/2/2	2/2/2	
Maximum Permissible Pressure	Refrigerant Side	MPa	1.02	1.02	1.02	1.02	1.02	1.02	1.02	1.02	1.02	
	Water Side	MPa	1.0	1.0	1.0	1.0	1.0	1.0	1.0	1.0	1.0	
Insulation			Polyethylene (19mm)									

Model			RCUF45 AZPY1	RCUF50 AZPY1	RCUF60 AZPY1	RCUF90 AZPY1	RCUF100 AZPY1	RCUF120 AZPY1	RCUF135 AZPY1	RCUF150 AZPY1	RCUF180 AZPY1	
Shell	Water Side	Shell Material	Steel									
		Outer Diameter	mm	392	392	356	394	394	441	482	482	394
		Length	mm	1,278	1,278	2,168	2,540	2,540	2,532	2,532	2,532	2,540
	Refrigerant Side	Shell Material	Steel									
		Outer Diameter	mm	412	412	362	412	412	462	512	512	412
		Length	mm	117	117	107	117	117	120	136	136	117
	Thickness	mm	6	6	6	6	6	6	6	6	6	
Tube	Material	Copper										
	Outer Diameter	mm	12.7	12.7	12.7	12.7	12.7	12.7	12.7	12.7	12.7	
	Quantity(No.1/No.2)	—	345	345	297	338	338	460	536	536	338/338	
	Number of Pass	—	4	4	4	2	2	2	2	2	2/2	
Maximum Permissible Pressure	Refrigerant Side	MPa	1.02	1.02	1.02	1.02	1.02	1.02	1.02	1.02	1.02	
	Water Side	MPa	1.0	1.0	1.0	1.0	1.0	1.0	1.0	1.0	1.0	
Insulation			Polyethylene (19 mm)									

Model			RCUF200 AZPY1	RCUF240 AZPY1	RCUF270 AZPY1	RCUF300 AZPY1	RCUF320 AZPY1	RCUF360 AZPY1	RCUF405 AZPY1	RCUF420 AZPY1	RCUF450 AZPY1	
Shell	Water Side	Shell Material	Steel									
		Outer Diameter	mm	394	441	482	482	394/441	441	482	482	482
		Length	mm	2,540	2,532	2,532	2,532	2540/2532	2,532	2,532	2,532	2,532
	Refrigerant Side	Shell Material	Steel									
		Outer Diameter	mm	412	462	512	512	412/462	462	512	512	512
		Length	mm	117	120	136	136	117/120	120	136	136	136
	Thickness	mm	6	6	6	6	6	6	6	6	6	
Tube	Material	Copper										
	Outer Diameter	mm	12.7	12.7	12.7	12.7	12.7	12.7	12.7	12.7	12.7	
	Quantity(No.1/No.2/No.3)	—	338/338	460/460	536/536	536/536	338/338/460	460/460/460	536/536/536	536/536/536	536/536/536	
	Number of Pass	—	2/2	2/2	2/2	2/2	2/2/2	2/2/2	2/2/2	2/2/2	2/2/2	
Maximum Permissible Pressure	Refrigerant Side	MPa	1.02	1.02	1.02	1.02	1.02	1.02	1.02	1.02	1.02	
	Water Side	MPa	1.0	1.0	1.0	1.0	1.0	1.0	1.0	1.0	1.0	
Insulation			Polyethylene (19 mm)									

Note: the data above is indicated for each water cooler, as these units greater than 200AZY1/ 180AZPY1 including 200AZY1/ 180AZPY1 consist of two or three water coolers, in the case the data for each water coolers are different, it is showed as no.1water cooler data + no.2 water cooler data+ no.3 water cooler data.

Refrigerant System

In addition to the basic air-cooled water chiller components (compressor, condenser, electronic expansive valves and water cooler), the following components are equipped in each refrigerant cycle:

Stop Valve for Compressor Discharge Line and Liquid Line:

These stop valves are equipped at the liquid line, and facilitate easy compressor service without appreciable leakage of refrigerant.

Capacity Control

All models are equipped with an unloading system for each compressor, in order to adjust the cooling capacity and provide precise temperature control for the chilled water, coupled with electric thermostat.

Electric Operation Control

The utilization of microcomputer makes Hitachi water-cooled chiller more advanced.

Control Panel

The control panel is equipped with starting button, stopping button, power light, operation indicating light, warning light, button for the operation within refrigerant circulatory system, warning displayer and checking. The control panel is installed in the place that is convenient to operate. Operation/warning displayer can show individual warning code, such as high pressure cut-off, low pressure cut-off, etc. This function is beneficial to checking warning that has occurred. Checking button is used to check temperature of chilled water and display the warning information. The adjustment of the chilling water, adjustment of temperature difference ON/OFF and long distance/site controlling are installed on the back of control panel in order to avoid being touched when the unit is operated.

Printed circuit board

Microcomputer, relay and electrical parts are installed on the printed circuit board. Therefore, it does not need the machinery parts and matched wires. It is undoubted that reliability has been improved. Because of adopting the microcomputer, printed circuit board includes multiple kinds of functions as below.

Screw Compressor Cycling Protection Circuit

When the temperature protection device is triggered to make the compressor restart after stopping of compressor, CCP will make the single compressor postpone for 3 minutes to start. To the unit with two or more compressors, when the first compressor is postponed starting for 3 minutes, another compressor will be started every one minute. Thus, it can avoid the damage caused by the circular operation of the compressors.

Electrical temperature detector

It is used to sense the temperature of the chilled water and operate the cooling capacity control magnetic valve of Hitachi screw compressor.

Screw compressor reverse phase protective circuit

The circuit is installed with reverse phase protective relay in order to prevent reverse rotation of compressors due to the error of phase sequence.

Operation of converting the compressor

If the unit has several compressors, the operation order of the compressors can be converted in order to balance the operating hours. Such function can prolong the span-life of the unit.

Restarting after temporary electrical power stopping

When the stopping of power supply is less than 2 seconds, the compressor can start after electrical power supply is recovered for 3 minutes.

Refrigerant Charge

AZY1 series

Model	RCUF45 AZY1	RCUF50 AZY1	RCUF60 AZY1	RCUF90 AZY1	RCUF100 AZY1	RCUF120 AZY1	RCUF150 AZY1	RCUF180 AZY1	RCUF200 AZY1
Refrigerant (kg)	54	54	60	54×2	54×2	62×2	58×3	62×3	54×2+54×2
Oil (L)	8	8	8	8×2	8×2	8×2	8×3	8×3	8×2+8×2
Model	RCUF220 AZY1	RCUF240 AZY1	RCUF270 AZY1	RCUF300 AZY1	RCUF330 AZY1	RCUF360 AZY1	RCUF400 AZY1	RCUF420 AZY1	RCUF450 AZY1
Refrigerant (kg)	62×2+54×2	62×2+62×2	58×3+62×2	58×3+58×3	62×3+58×3	62×3+62×3	58×3+58×3+54×2	58×3+58×3+62×2	58×3+58×3+58×3
Oil (L)	8×2+8×2	8×2+8×2	8×3+8×2	8×3+8×3	8×3+8×3	8×3+8×3	8×3+8×3+8×2	8×3+8×3+8×2	8×3+8×3+8×3

AZPY1 series

Model	RCUF45 AZPY1	RCUF50 AZPY1	RCUF60 AZPY1	RCUF90 AZPY1	RCUF100 AZPY1	RCUF120 AZPY1	RCUF135 AZPY1	RCUF150 AZPY1	RCUF180 AZPY1
Refrigerant (kg)	58	58	70	58×2	58×2	70×2	58×3	58×3	58×2+58×2
Oil (L)	8	8	8	8×2	8×2	8×2	8×3	8×3	8×2+8×2
Model	RCUF200 AZPY1	RCUF240 AZPY1	RCUF270 AZPY1	RCUF300 AZPY1	RCUF320 AZPY1	RCUF360 AZPY1	RCUF405 AZPY1	RCUF420 AZPY1	RCUF450 AZPY1
Refrigerant (kg)	58×2+58×2	70×2+70×2	58×3+58×3	58×3+58×3	58×2+58×2+70×2	70×2+70×2+70×2	58×3+58×3+58×3	58×3+58×3+58×3	58×3+58×3+58×3
Oil (L)	8×2+8×2	8×2+8×2	8×3+8×3	8×3+8×3	8×2+8×2+8×2	8×2+8×2+8×2	8×3+8×3+8×3	8×3+8×3+8×3	8×3+8×3+8×3

Note: for the details of the blank places, please contact HITACHI or Hitachi's distributors.

Protection and Safety Control

The safety and protective devices are equipped in the unit to ensure dependable and long life operation. Their functions should be carefully noted, and field adjustment is not recommended, if the setting is maintained at the point listed in the table.

Compressor Protection

1. The high pressure switch and the low pressure control protect against excessive discharge pressure and exceedingly low suction pressure. The switch and control cut out compressor operation when the discharge pressure exceeds the setting or when the suction pressure decrease below the setting.
2. Overcurrent relays equipped in the magnetic switch box cut out each compressor operation when the current to the compressor exceeds the setting.
3. The internal thermostat embedded in the compressor motor winding cuts out each operations, when the temperature of the motor winding exceeds the setting.
4. An oil heater in the compressor prevents oil from foaming during cold starting. Energize this heater to warm the oil, while the compressor is stopped.

Fan Motor Protection

The thermal overcurrent relays for the condenser fan motors cut out fan operation and compressor operation, when the current to the fan motor exceeds the setting.

Refrigerant Cycle

1. The fusible plug is equipped on the liquid line. When refrigerant temperature exceeds the melting point, the plug melts and purges the refrigerant gas, in order to avoid explosion of the condenser.
2. The freeze protection control, in which the sensor is located in the water outlet near the water cooler, cuts out the compressor operation, when the water outlet temperature decreases below the setting.

14. Safety and Control Devices Setting

Model		RCUF45 AZY1	RCUF50 AZY1	RCUF60 AZY1	RCUF90 AZY1	RCUF100 AZY1	RCUF120 AZY1	RCUF150 AZY1	RCUF180 AZY1	RCUF200 AZY1	
For Compressor	High Pressure Control	Manual Reset, Adjustable(One Switch for Each Compressor Motor)									
	Cut-Out	MPa	2.0	2.0	2.0	2.0	2.0	2.0	2.0	2.0	
	Low Pressure Control	Control by Micro-Processor									
	Cut-Out	MPa	0.01	0.01	0.01	0.01	0.01	0.01	0.01	0.01	
	Internal Thermostat	Automatic Reset, Non-Adjustable(One Switch for Each Compressor Motor)									
	Cut-Out	℃	150	150	150	150	150	150	150	150	
	Cut-In	℃	93	93	93	93	93	93	93	93	
	Overcurrent Relay *1	Manual Reset, Adjustable(One Switch for Each Compressor Motor)									
	380V 50Hz	A	72	80	100	72	80	100	80	100	80
	Oil Heater	One Oil Heater for Each Compressor Motor									
	Capacity	W	150	150	150	150	150	150	150	150	150
	CCP Timer	Non-Adjustable (One Timer for Each Compressor Motor)									
Setting Time	sec.	180	180	180	180	180	180	180	180	180	
Star-Delta Starting	sec.	5	5	5	5	5	5	5	5	5	
From Start to Load-up	sec.	30	30	30	30	30	30	30	30	30	
For Control Circuit	Fuse Capacity(220V/240V)	A	4	4	4	4	4	4	4	4	
For Refrigerant Circuit	Fusible Plug	(One for Each Circuit)									
	Melting Temperature	℃	72	72	72	72	72	72	72	72	
	Freeze Protection Control	℃	1	1	1	1	1	1	1	1	
	Cut-Out	℃	1	1	1	1	1	1	1	1	
Discharge Temperature Control	℃	140	140	140	140	140	140	140	140	140	
Overcurrent Relay for Motor of Fan	Manual Reset, Adjustable(One Three-Phase Set for Each Fan Motor)										
380V/415V 50Hz	A	3.3	3.3	3.3	3.3	3.3	3.3	3.3	3.3	3.3	
Pressure Relief Valve	(One for Each Circuit)										
Starting to Open	MPa	1.02	1.02	1.02	1.02	1.02	1.02	1.02	1.02	1.02	
Model		RCUF220 AZY1	RCUF240 AZY1	RCUF270 AZY1	RCUF300 AZY1	RCUF330 AZY1	RCUF360 AZY1	RCUF400 AZY1	RCUF420 AZY1	RCUF450 AZY1	
For Compressor	High Pressure Control	Manual Reset, Adjustable(One Switch for Each Compressor Motor)									
	Cut-Out	MPa	2.0	2.0	2.0	2.0	2.0	2.0	2.0	2.0	
	Low Pressure Control	Control by Micro-Processor									
	Cut-Out	MPa	0.01	0.01	0.01	0.01	0.01	0.01	0.01	0.01	
	Internal Thermostat	Automatic Reset, Non-Adjustable(One Switch for Each Compressor Motor)									
	Cut-Out	℃	150	150	150	150	150	150	150	150	
	Cut-In	℃	93	93	93	93	93	93	93	93	
	Overcurrent Relay *1	Manual Reset, Adjustable(One Switch for Each Compressor Motor)									
	380V 50Hz	A	100/80	100	80/100	80	100/80	100	80	80/80/100	80
	Oil Heater	One Oil Heater for Each Compressor Motor									
	Capacity	W	150	150	150	150	150	150	150	150	150
	CCP Timer	Non-Adjustable (One Timer for Each Compressor Motor)									
Setting Time	sec.	180	180	180	180	180	180	180	180	180	
Star-Delta Starting	sec.	5	5	5	5	5	5	5	5	5	
From Start to Load-up	sec.	30	30	30	30	30	30	30	30	30	
For Control Circuit	Fuse Capacity(220V/240V)	A	4	4	4	4	4	4	4	4	
For Refrigerant Circuit	Fusible Plug	(One for Each Circuit)									
	Melting Temperature	℃	72	72	72	72	72	72	72	72	
	Freeze Protection Control	℃	1	1	1	1	1	1	1	1	
	Cut-Out	℃	1	1	1	1	1	1	1	1	
Discharge Temperature Control	℃	140	140	140	140	140	140	140	140	140	
Overcurrent Relay for Motor of Fan	Manual Reset, Adjustable(One Three-Phase Set for Each Fan Motor)										
380V/415V 50Hz	A	3.3	3.3	3.3	3.3	3.3	3.3	3.3	3.3	3.3	
Pressure Relief Valve	(One for Each Circuit)										
Starting to Open	MPa	1.02	1.02	1.02	1.02	1.02	1.02	1.02	1.02	1.02	

Note: The data marked with *1 is indicated for each compressor, as in a module the same compressors are used, for these chillers greater than 200AZY1 including 200AZY1 which consist of two or three modules, when the data for the compressor in the two or three modules are different, it is showed as data for one of the compressor in the no.1 module / data for one of the compressor in the no.2 module/ data for one of the compressor in the no.3 module.

Model		RCUF45 AZPY1	RCUF50 AZPY1	RCUF60 AZPY1	RCUF90 AZPY1	RCUF100 AZPY1	RCUF120 AZPY1	RCUF135 AZPY1	RCUF150 AZPY1	RCUF180 AZPY1	
For Compressor	High Pressure Control	Manual Reset, Adjustable(One Switch for Each Compressor Motor)									
	Cut-Out	MPa	2.0	2.0	2.0	2.0	2.0	2.0	2.0	2.0	
	Low Pressure Control	Control by Micro-Processor									
	Cut-Out	MPa	0.01	0.01	0.01	0.01	0.01	0.01	0.01	0.01	
	Internal Thermostat	Automatic Reset, Non-Adjustable(One Switch for Each Compressor Motor)									
	Cut-Out	°C	150	150	150	150	150	150	150	150	
	Cut-In	°C	93	93	93	93	93	93	93	93	
	Overcurrent Relay *1	Manual Reset, Adjustable(One Switch for Each Compressor Motor)									
	380V 50Hz	A	72	80	100	72	80	100	72	80	72
	Oil Heater	One Oil Heater for Each Compressor Motor									
	Capacity	W	150	150	150	150	150	150	150	150	150
	CCP Timer	Non-Adjustable (One Timer for Each Compressor Motor)									
Setting Time	sec.	180	180	180	180	180	180	180	180	180	
Star-Delta Starting	sec.	5	5	5	5	5	5	5	5	5	
From Start to Load-up	sec.	30	30	30	30	30	30	30	30	30	
For Control Circuit	Fuse Capacity(220V/240V)	A	4	4	4	4	4	4	4	4	
For Refrigerant Circuit	Fusible Plug	(One for Each Circuit)									
	Melting Temperature	°C	72	72	72	72	72	72	72	72	
	Freeze Protection Control	°C	1	1	1	1	1	1	1	1	
	Cut-Out	°C	1	1	1	1	1	1	1	1	
Discharge Temperature Control	°C	140	140	140	140	140	140	140	140	140	
Overcurrent Relay for Motor of Fan	Manual Reset, Adjustable(One Three-Phase Set for Each Fan Motor)										
380V/415V 50Hz	A	3.3	3.3	3.3	3.3	3.3	3.3	3.3	3.3	3.3	
Pressure Relief Valve	(One for Each Circuit)										
Starting to Open	MPa	1.02	1.02	1.02	1.02	1.02	1.02	1.02	1.02	1.02	
Model		RCUF200 AZPY1	RCUF240 AZPY1	RCUF270 AZPY1	RCUF300 AZPY1	RCUF320 AZPY1	RCUF360 AZPY1	RCUF405 AZPY1	RCUF420 AZPY1	RCUF450 AZPY1	
For Compressor	High Pressure Control	Manual Reset, Adjustable(One Switch for Each Compressor Motor)									
	Cut-Out	MPa	2.0	2.0	2.0	2.0	2.0	2.0	2.0	2.0	
	Low Pressure Control	Control by Micro-Processor									
	Cut-Out	MPa	0.01	0.01	0.01	0.01	0.01	0.01	0.01	0.01	
	Internal Thermostat	Automatic Reset, Non-Adjustable(One Switch for Each Compressor Motor)									
	Cut-Out	°C	150	150	150	150	150	150	150	150	
	Cut-In	°C	93	93	93	93	93	93	93	93	
	Overcurrent Relay *1	Manual Reset, Adjustable(One Switch for Each Compressor Motor)									
	380V 50Hz	A	80	100	72	80	80/80/100	100	72	80/72/72	80
	Oil Heater	One Oil Heater for Each Compressor Motor									
	Capacity	W	150	150	150	150	150	150	150	150	150
	CCP Timer	Non-Adjustable (One Timer for Each Compressor Motor)									
Setting Time	sec.	180	180	180	180	180	180	180	180	180	
Star-Delta Starting	sec.	5	5	5	5	5	5	5	5	5	
From Start to Load-up	sec.	30	30	30	30	30	30	30	30	30	
For Control Circuit	Fuse Capacity(220V/240V)	A	4	4	4	4	4	4	4	4	
For Refrigerant Circuit	Fusible Plug	(One for Each Circuit)									
	Melting Temperature	°C	72	72	72	72	72	72	72	72	
	Freeze Protection Control	°C	1	1	1	1	1	1	1	1	
	Cut-Out	°C	1	1	1	1	1	1	1	1	
Discharge Temperature Control	°C	140	140	140	140	140	140	140	140	140	
Overcurrent Relay for Motor of Fan	Manual Reset, Adjustable(One Three-Phase Set for Each Fan Motor)										
380V/415V 50Hz	A	3.3	3.3	3.3	3.3	3.3	3.3	3.3	3.3	3.3	
Pressure Relief Valve	(One for Each Circuit)										
Starting to Open	MPa	1.02	1.02	1.02	1.02	1.02	1.02	1.02	1.02	1.02	

Note: The data marked with *1 is indicated for each compressor, as in a module the same compressors are used, for these chillers greater than 180AZPY1 including 180AZPY1 which consist of two or three modules, when the data for the compressor in the two or three modules are different, it is showed as data for one of the compressor in the no.1 module / data for one of the compressor in the no.2 module/ data for one of the compressor in the no.3 module.

15. Electrical Wiring Diagram

MODELS: RCUF45AZY1, RCUF50AZY1, RCUF60AZY1, RCUF45AZPY1, RCUF50AZPY1

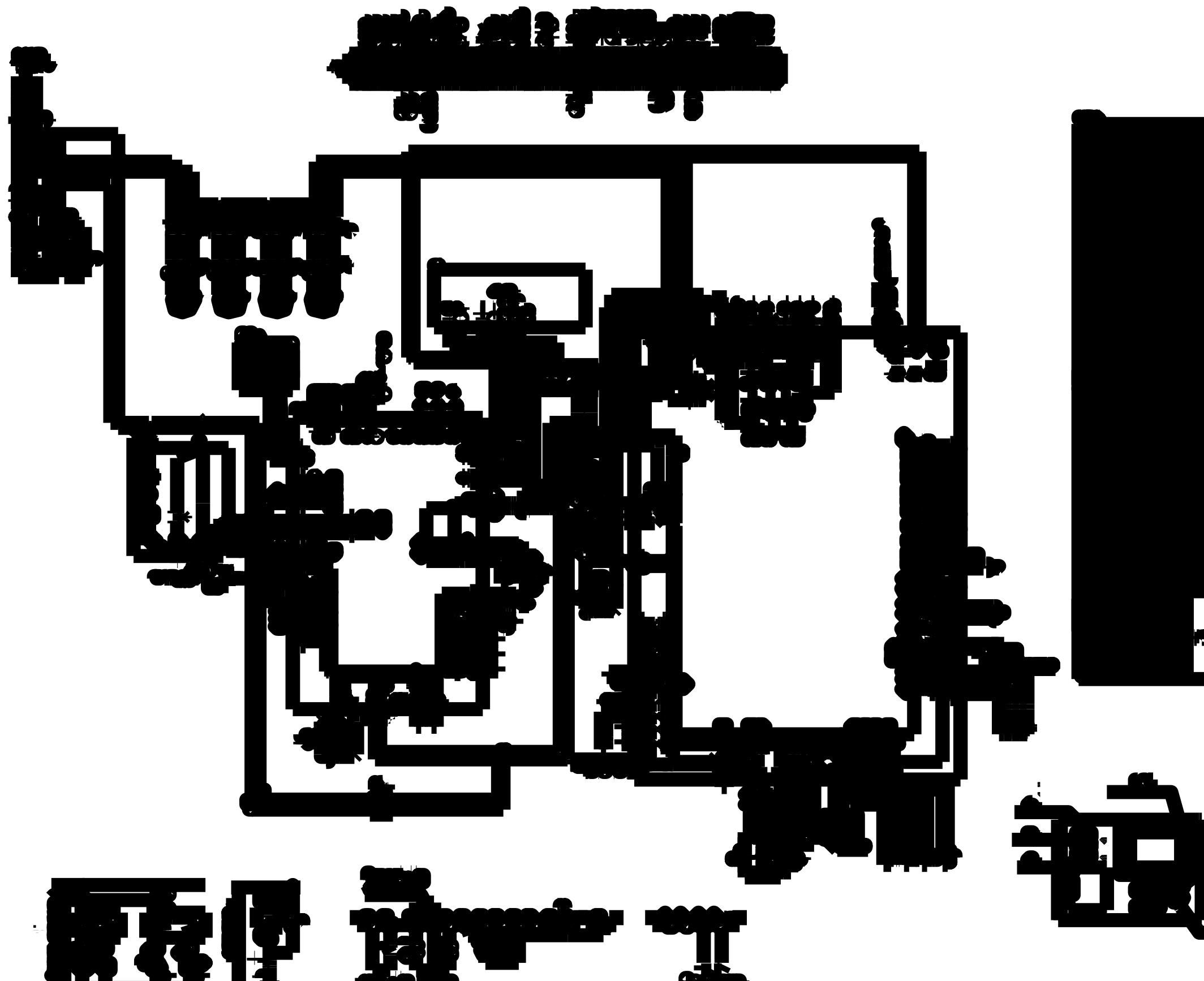

MODELS: RCUF60AZPY1

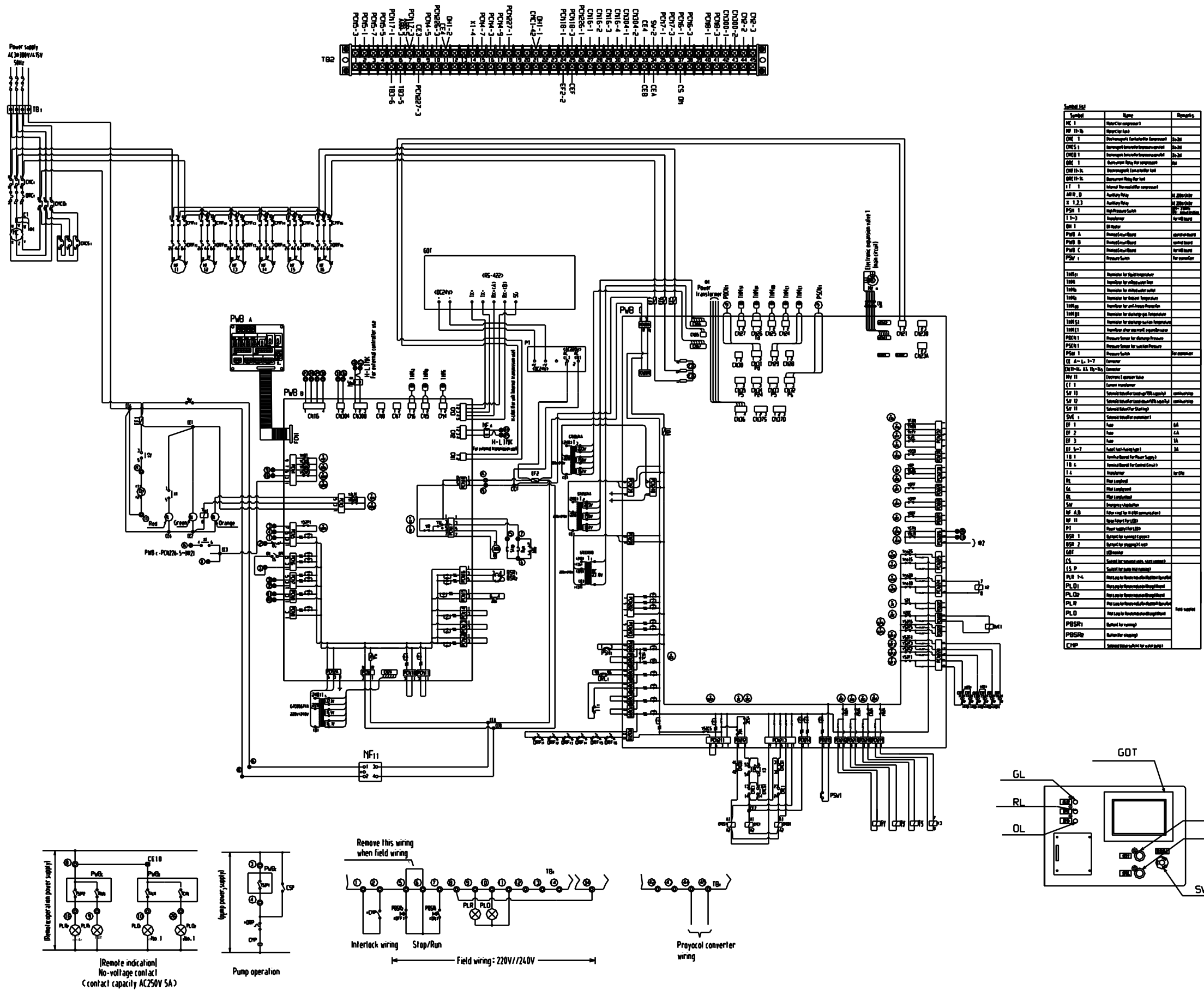

Symbol list	Name	Remarks
AC	AC input	
CMC-1	Compressor 1	
CMC-2	Compressor 2	
CMC-3	Compressor 3	
CMC-4	Compressor 4	
CMC-5	Compressor 5	
CMC-6	Compressor 6	
CMC-7	Compressor 7	
CMC-8	Compressor 8	
CMC-9	Compressor 9	
CMC-10	Compressor 10	
CMC-11	Compressor 11	
CMC-12	Compressor 12	
CMC-13	Compressor 13	
CMC-14	Compressor 14	
CMC-15	Compressor 15	
CMC-16	Compressor 16	
CMC-17	Compressor 17	
CMC-18	Compressor 18	
CMC-19	Compressor 19	
CMC-20	Compressor 20	
CMC-21	Compressor 21	
CMC-22	Compressor 22	
CMC-23	Compressor 23	
CMC-24	Compressor 24	
CMC-25	Compressor 25	
CMC-26	Compressor 26	
CMC-27	Compressor 27	
CMC-28	Compressor 28	
CMC-29	Compressor 29	
CMC-30	Compressor 30	
CMC-31	Compressor 31	
CMC-32	Compressor 32	
CMC-33	Compressor 33	
CMC-34	Compressor 34	
CMC-35	Compressor 35	
CMC-36	Compressor 36	
CMC-37	Compressor 37	
CMC-38	Compressor 38	
CMC-39	Compressor 39	
CMC-40	Compressor 40	
CMC-41	Compressor 41	
CMC-42	Compressor 42	
CMC-43	Compressor 43	
CMC-44	Compressor 44	
CMC-45	Compressor 45	
CMC-46	Compressor 46	
CMC-47	Compressor 47	
CMC-48	Compressor 48	
CMC-49	Compressor 49	
CMC-50	Compressor 50	
CMC-51	Compressor 51	
CMC-52	Compressor 52	
CMC-53	Compressor 53	
CMC-54	Compressor 54	
CMC-55	Compressor 55	
CMC-56	Compressor 56	
CMC-57	Compressor 57	
CMC-58	Compressor 58	
CMC-59	Compressor 59	
CMC-60	Compressor 60	
CMC-61	Compressor 61	
CMC-62	Compressor 62	
CMC-63	Compressor 63	
CMC-64	Compressor 64	
CMC-65	Compressor 65	
CMC-66	Compressor 66	
CMC-67	Compressor 67	
CMC-68	Compressor 68	
CMC-69	Compressor 69	
CMC-70	Compressor 70	
CMC-71	Compressor 71	
CMC-72	Compressor 72	
CMC-73	Compressor 73	
CMC-74	Compressor 74	
CMC-75	Compressor 75	
CMC-76	Compressor 76	
CMC-77	Compressor 77	
CMC-78	Compressor 78	
CMC-79	Compressor 79	
CMC-80	Compressor 80	
CMC-81	Compressor 81	
CMC-82	Compressor 82	
CMC-83	Compressor 83	
CMC-84	Compressor 84	
CMC-85	Compressor 85	
CMC-86	Compressor 86	
CMC-87	Compressor 87	
CMC-88	Compressor 88	
CMC-89	Compressor 89	
CMC-90	Compressor 90	
CMC-91	Compressor 91	
CMC-92	Compressor 92	
CMC-93	Compressor 93	
CMC-94	Compressor 94	
CMC-95	Compressor 95	
CMC-96	Compressor 96	
CMC-97	Compressor 97	
CMC-98	Compressor 98	
CMC-99	Compressor 99	
CMC-100	Compressor 100	

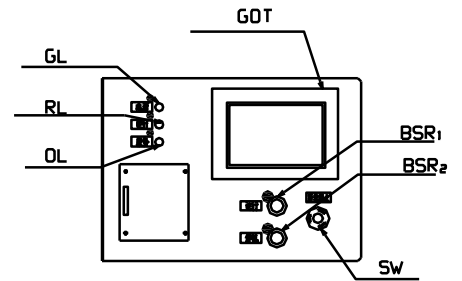
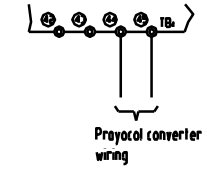
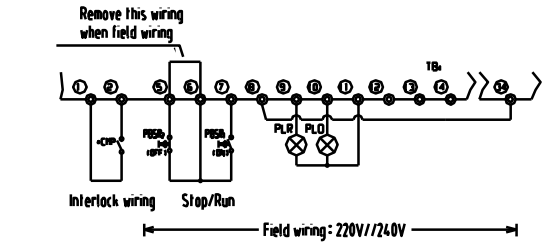
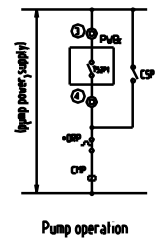
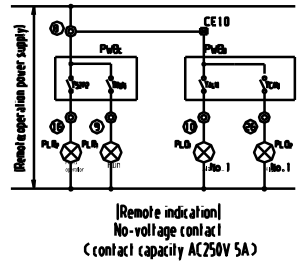

MODELS: RCUF90, 100, 120, 200, 220, 240AZY1; RCUF270AZY1-2; RCUF400AZY1-3; RCUF420AZY1-3
 RCUF90, 100, 180, 200AZPY1; RCUF320AZPY1-1; RCUF320AZPY1-2

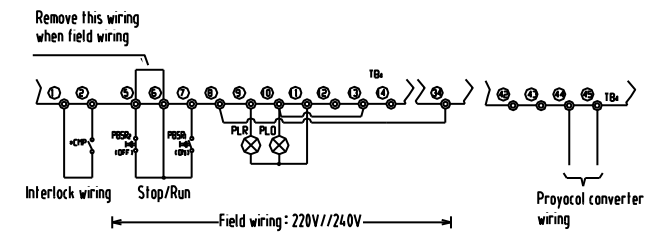
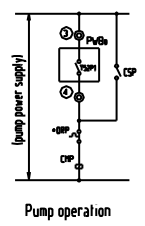
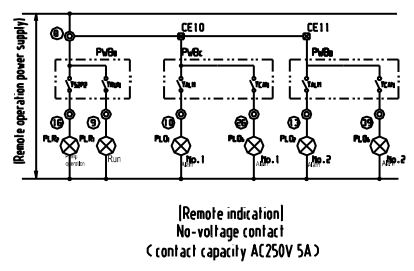
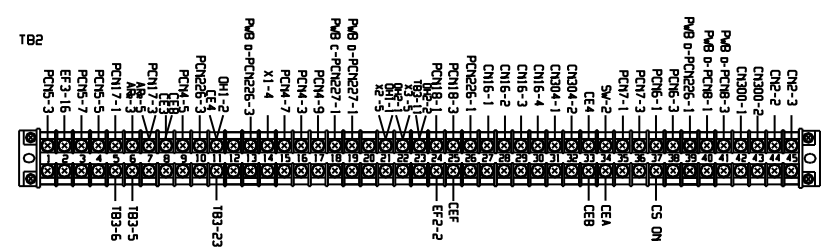
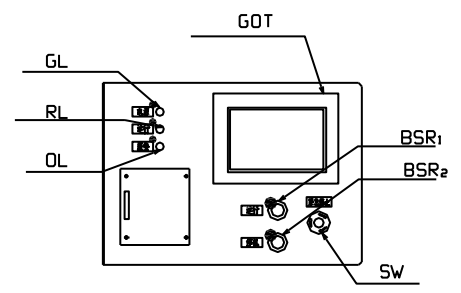
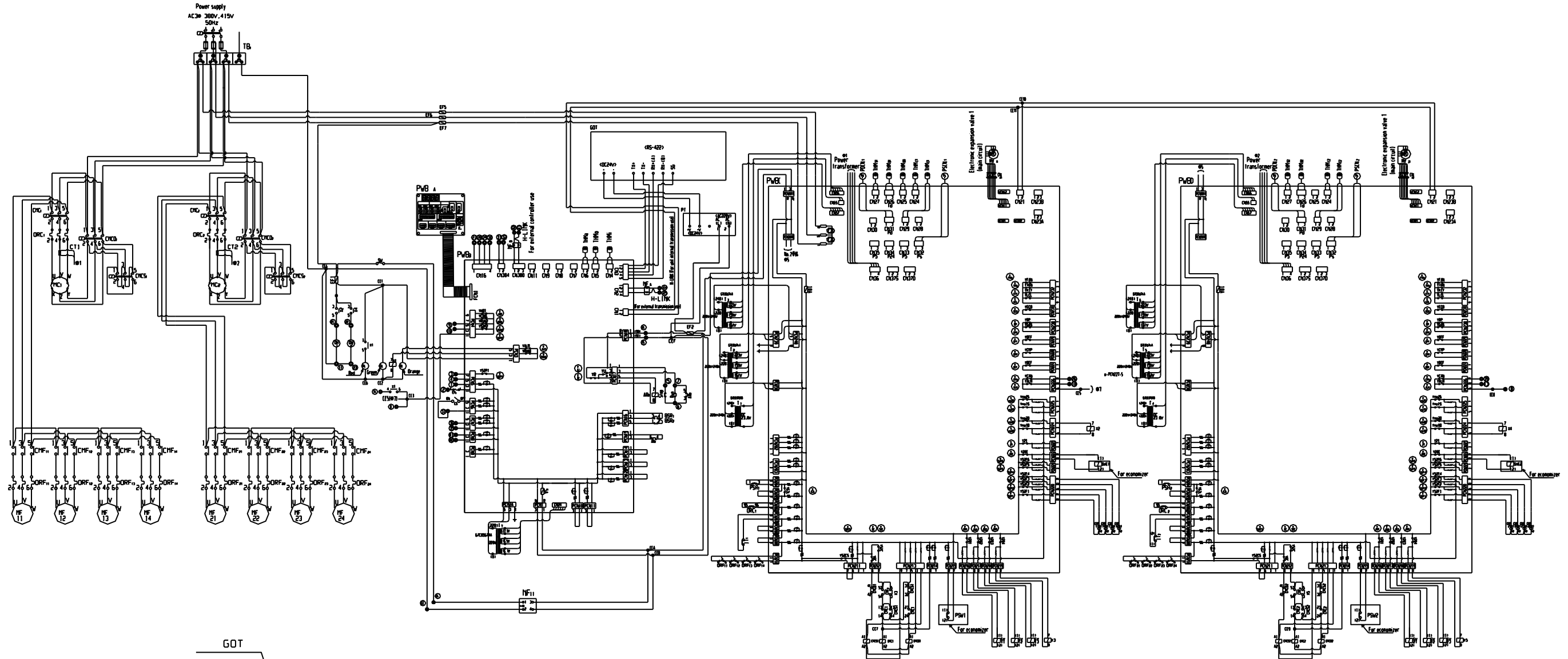

Symbol	Name	Remarks
CE 0-10	Connector	
CE 10-15	Connector	
EM 0-10	Electronic Expansion Valve	
CT 1-2	Current transformer	
SME 0	Solenoid Valve for recovery	
SV 0-2	Solenoid Valve for start-up (P/W control)	common
SV 0-3	Solenoid Valve for start-up (P/W control)	common
SV 0-4	Solenoid Valve for start-up	common
EF 0-10-15	Fuse	32A
EF 0-16	Fuse	15A
EF 1	Fuse	6A
EF 2	Fuse	4A
EF 3	Fuse	1.5A
EF 0-4	Fuse (High-Speed type)	3A
TB 1	Terminal Board for Power Supply	
TB 2	Terminal Board for Control Panel	
TR 1	Transformer	for P/W
RL	Refrigerant Liquid	
GL	Refrigerant Gas	
PL	Pressure Limit	
SW	Emergency Stop Button	
WF 0-8	Water flow sensor for P/W control	
WT 0-8	Water flow sensor for P/W control	
PWR 1	Power Supply for P/W	
PWR 2	Power Supply for P/W	
BSR 1	Refrigerant level sensor	
BSR 2	Refrigerant level sensor	
GOT	Graphic Operator Terminal	
CS 1-5	Control Switch	AC 220V/240V
CSP	Control Switch for pump	
PLR1-2	Pressure Limit Relay for P/W control	
PLD1-2	Pressure Limit Relay for P/W control	
PLD1-3	Pressure Limit Relay for P/W control	
PLR	Pressure Limit Relay	
PLD	Pressure Limit Relay	
PSSR1	Pressure Sensor	
PSSR2	Pressure Sensor	
CMP	Control Panel	

Symbol	Name	Remarks
RC 0	Refrigerant level sensor	
ORC 0	Overcurrent Relay for expansion valve	for P/W
ORC1-2	Overcurrent Relay for expansion valve	for P/W
ORC3-4	Overcurrent Relay for expansion valve	for P/W
ORC 0	Overcurrent Relay for expansion valve	for P/W
CT 1-2	Current transformer	
SM 0	Solenoid Valve for start-up	
SV 0-2	Solenoid Valve for start-up	
SV 0-3	Solenoid Valve for start-up	
SV 0-4	Solenoid Valve for start-up	
EF 0-10-15	Fuse	32A
EF 0-16	Fuse	15A
EF 1	Fuse	6A
EF 2	Fuse	4A
EF 3	Fuse	1.5A
EF 0-4	Fuse (High-Speed type)	3A
TB 1	Terminal Board for Power Supply	
TB 2	Terminal Board for Control Panel	
TR 1	Transformer	for P/W
RL	Refrigerant Liquid	
GL	Refrigerant Gas	
PL	Pressure Limit	
SW	Emergency Stop Button	
WF 0-8	Water flow sensor for P/W control	
WT 0-8	Water flow sensor for P/W control	
PWR 1	Power Supply for P/W	
PWR 2	Power Supply for P/W	
BSR 1	Refrigerant level sensor	
BSR 2	Refrigerant level sensor	
GOT	Graphic Operator Terminal	
CS 1-5	Control Switch	AC 220V/240V
CSP	Control Switch for pump	
PLR1-2	Pressure Limit Relay for P/W control	
PLD1-2	Pressure Limit Relay for P/W control	
PLD1-3	Pressure Limit Relay for P/W control	
PLR	Pressure Limit Relay	
PLD	Pressure Limit Relay	
PSSR1	Pressure Sensor	
PSSR2	Pressure Sensor	
CMP	Control Panel	

MODELS: RCUF120AZPY1, RCUF240AZPY1, RCUF320AZPY1-3, RCUF360AZPY1

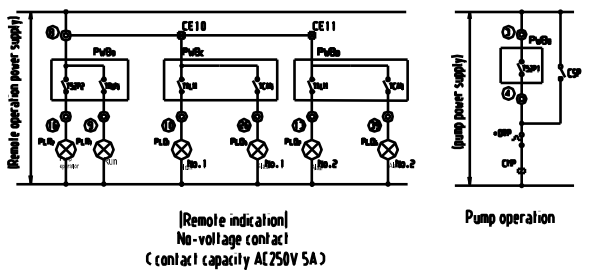
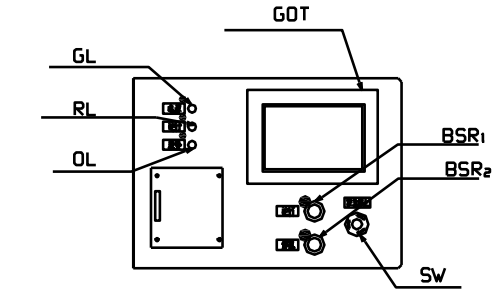
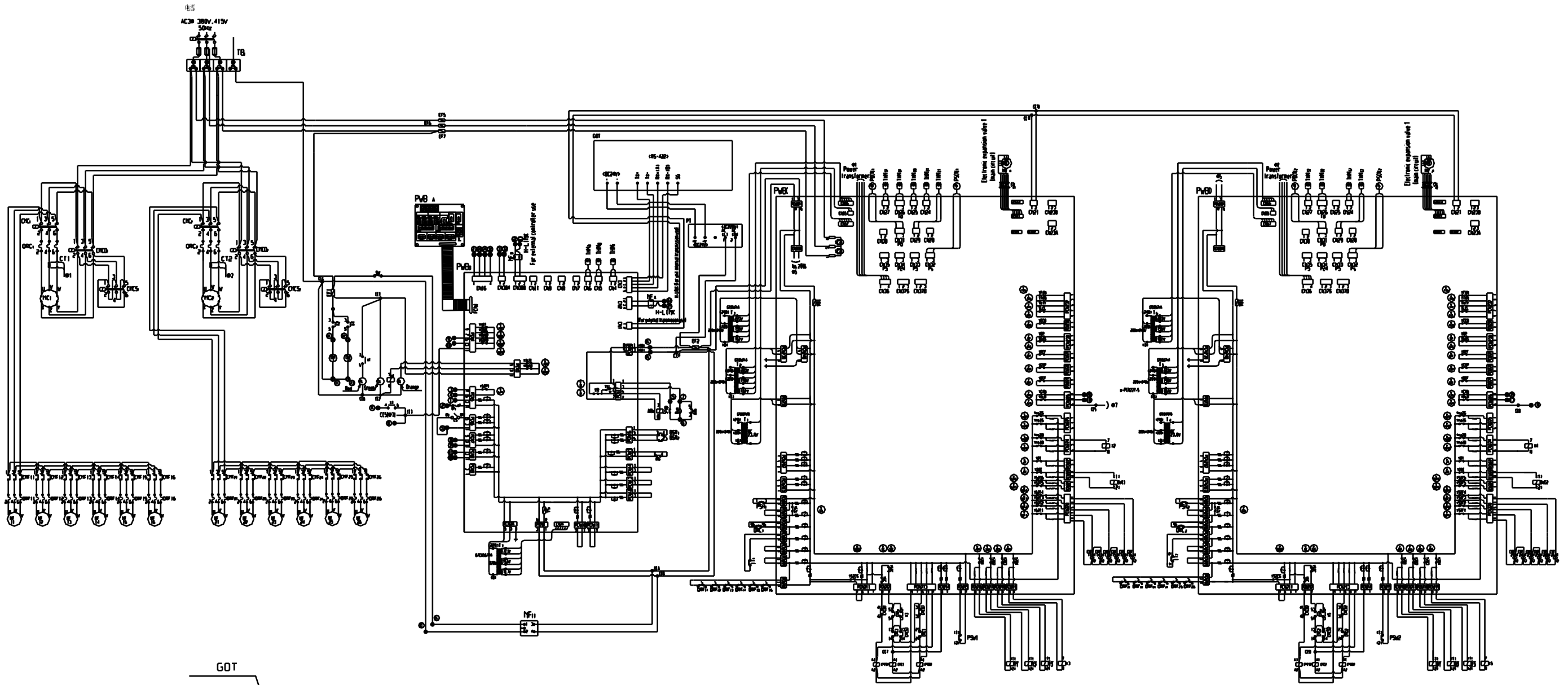

[Remote indication] No-voltage contact! Contact capacity AC250V 5A

Pump operation

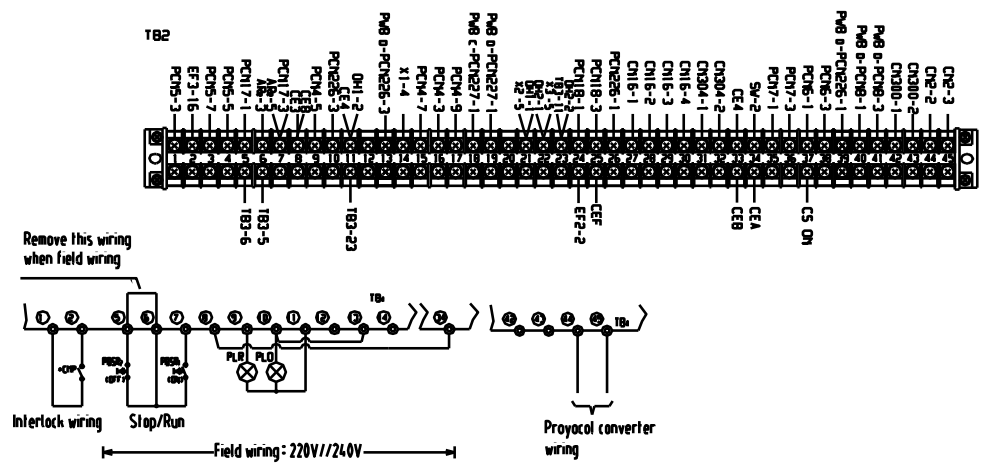

Remove this wiring when field wiring

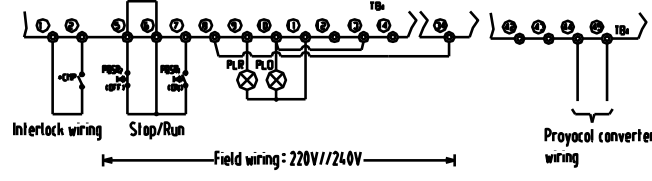

Field wiring: 220V/240V

Symbol	Name	Remarks
CR-3	Control relay	
CR-2	Control relay	
CR-1	Control relay	
C1	Contact	
C2	Contact	
C3	Contact	
CB1	Circuit breaker	
CB2	Circuit breaker	
CB3	Circuit breaker	
F1	Fuse	
F2	Fuse	
F3	Fuse	
SW	Stop/Run switch	
PC	Proyocall converter	
TS1	Temperature sensor	
TS2	Temperature sensor	
TS3	Temperature sensor	
TS4	Temperature sensor	
TS5	Temperature sensor	
PS1	Pressure switch	
PS2	Pressure switch	
PS3	Pressure switch	
PS4	Pressure switch	
PS5	Pressure switch	
AR1	Auxiliary relay	
AR2	Auxiliary relay	
BSR1	Bypass stop relay	
BSR2	Bypass stop relay	
GL	General lock	
RL	Remote lock	
OL	Overload	
CE10	Contact	
CE11	Contact	
CE12	Contact	
CE13	Contact	
CE14	Contact	
CE15	Contact	
CE16	Contact	
CE17	Contact	
CE18	Contact	
CE19	Contact	
CE20	Contact	
CE21	Contact	
CE22	Contact	
CE23	Contact	
CE24	Contact	
CE25	Contact	
CE26	Contact	
CE27	Contact	
CE28	Contact	
CE29	Contact	
CE30	Contact	
CE31	Contact	
CE32	Contact	
CE33	Contact	
CE34	Contact	
CE35	Contact	
CE36	Contact	
CE37	Contact	
CE38	Contact	
CE39	Contact	
CE40	Contact	
CE41	Contact	
CE42	Contact	
CE43	Contact	
CE44	Contact	
CE45	Contact	
CE46	Contact	
CE47	Contact	
CE48	Contact	
CE49	Contact	
CE50	Contact	
CE51	Contact	
CE52	Contact	
CE53	Contact	
CE54	Contact	
CE55	Contact	
CE56	Contact	
CE57	Contact	
CE58	Contact	
CE59	Contact	
CE60	Contact	
CE61	Contact	
CE62	Contact	
CE63	Contact	
CE64	Contact	
CE65	Contact	
CE66	Contact	
CE67	Contact	
CE68	Contact	
CE69	Contact	
CE70	Contact	
CE71	Contact	
CE72	Contact	
CE73	Contact	
CE74	Contact	
CE75	Contact	
CE76	Contact	
CE77	Contact	
CE78	Contact	
CE79	Contact	
CE80	Contact	
CE81	Contact	
CE82	Contact	
CE83	Contact	
CE84	Contact	
CE85	Contact	
CE86	Contact	
CE87	Contact	
CE88	Contact	
CE89	Contact	
CE90	Contact	
CE91	Contact	
CE92	Contact	
CE93	Contact	
CE94	Contact	
CE95	Contact	
CE96	Contact	
CE97	Contact	
CE98	Contact	
CE99	Contact	
CE100	Contact	

Symbol	Name	Remarks
CR-3	Control relay	
CR-2	Control relay	
CR-1	Control relay	
C1	Contact	
C2	Contact	
C3	Contact	
CB1	Circuit breaker	
CB2	Circuit breaker	
CB3	Circuit breaker	
F1	Fuse	
F2	Fuse	
F3	Fuse	
SW	Stop/Run switch	
PC	Proyocall converter	
TS1	Temperature sensor	
TS2	Temperature sensor	
TS3	Temperature sensor	
TS4	Temperature sensor	
TS5	Temperature sensor	
PS1	Pressure switch	
PS2	Pressure switch	
PS3	Pressure switch	
PS4	Pressure switch	
PS5	Pressure switch	
AR1	Auxiliary relay	
AR2	Auxiliary relay	
BSR1	Bypass stop relay	
BSR2	Bypass stop relay	
GL	General lock	
RL	Remote lock	
OL	Overload	
CE10	Contact	
CE11	Contact	
CE12	Contact	
CE13	Contact	
CE14	Contact	
CE15	Contact	
CE16	Contact	
CE17	Contact	
CE18	Contact	
CE19	Contact	
CE20	Contact	
CE21	Contact	
CE22	Contact	
CE23	Contact	
CE24	Contact	
CE25	Contact	
CE26	Contact	
CE27	Contact	
CE28	Contact	
CE29	Contact	
CE30	Contact	
CE31	Contact	
CE32	Contact	
CE33	Contact	
CE34	Contact	
CE35	Contact	
CE36	Contact	
CE37	Contact	
CE38	Contact	
CE39	Contact	
CE40	Contact	
CE41	Contact	
CE42	Contact	
CE43	Contact	
CE44	Contact	
CE45	Contact	
CE46	Contact	
CE47	Contact	
CE48	Contact	
CE49	Contact	
CE50	Contact	
CE51	Contact	
CE52	Contact	
CE53	Contact	
CE54	Contact	
CE55	Contact	
CE56	Contact	
CE57	Contact	
CE58	Contact	
CE59	Contact	
CE60	Contact	
CE61	Contact	
CE62	Contact	
CE63	Contact	
CE64	Contact	
CE65	Contact	
CE66	Contact	
CE67	Contact	
CE68	Contact	
CE69	Contact	
CE70	Contact	
CE71	Contact	
CE72	Contact	
CE73	Contact	
CE74	Contact	
CE75	Contact	
CE76	Contact	
CE77	Contact	
CE78	Contact	
CE79	Contact	
CE80	Contact	
CE81	Contact	
CE82	Contact	
CE83	Contact	
CE84	Contact	
CE85	Contact	
CE86	Contact	
CE87	Contact	
CE88	Contact	
CE89	Contact	
CE90	Contact	
CE91	Contact	
CE92	Contact	
CE93	Contact	
CE94	Contact	
CE95	Contact	
CE96	Contact	
CE97	Contact	
CE98	Contact	
CE99	Contact	
CE100	Contact	

MODELS: RCUF150, 180, 300, 330, 360, 450AZY1; RCUF135, 150, 270, 300, 405, 420, 450AZPY1
RCUF270AZY1-1; RCUF400AZY1-1; RCUF400AZY1-2; RCUF420AZY1-1; RCUF420AZY1-2

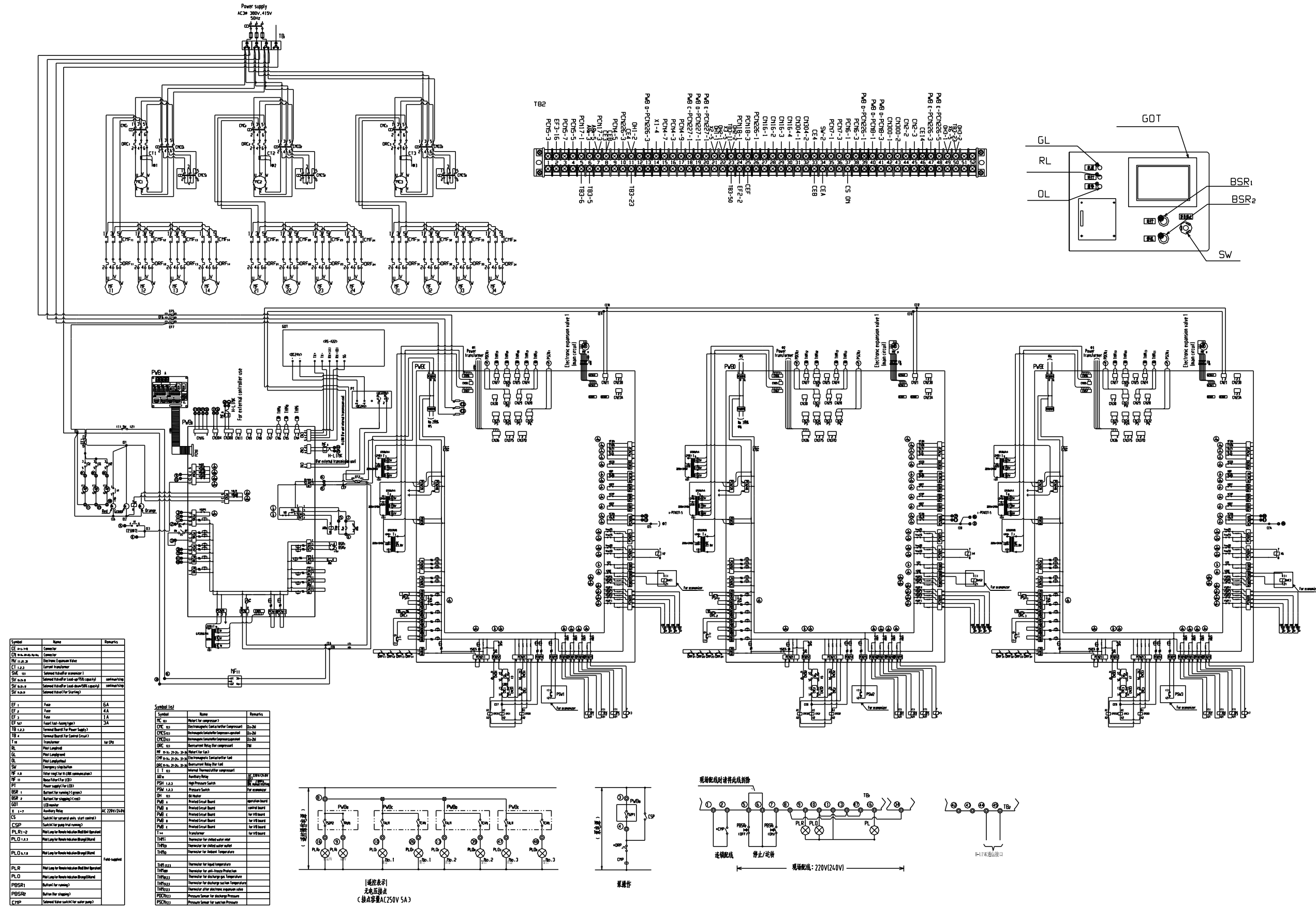

Symbol	Name	Remarks
CS	1.1-2	Connector
CS	1.1-3	Connector
EV	1.1-3	Electronic Expansion Valve
CT	1.1-3	Current Transformer
CSV	1.1	Sensor (Vibration / Pressure)
SV	1.1-3	Sensor (Vibration / Pressure)
SV	1.1-3	Sensor (Vibration / Pressure)
SV	1.1-3	Sensor (Vibration / Pressure)
EF	1	Fuse
EF	2	Fuse
EF	3	Fuse
EF	4	Fuse
EF	5	Fuse
EF	6	Fuse
EF	7	Fuse
EF	8	Fuse
EF	9	Fuse
EF	10	Fuse
EF	11	Fuse
EF	12	Fuse
EF	13	Fuse
EF	14	Fuse
EF	15	Fuse
EF	16	Fuse
EF	17	Fuse
EF	18	Fuse
EF	19	Fuse
EF	20	Fuse
EF	21	Fuse
EF	22	Fuse
EF	23	Fuse
EF	24	Fuse
EF	25	Fuse
EF	26	Fuse
EF	27	Fuse
EF	28	Fuse
EF	29	Fuse
EF	30	Fuse
EF	31	Fuse
EF	32	Fuse
EF	33	Fuse
EF	34	Fuse
EF	35	Fuse
EF	36	Fuse
EF	37	Fuse
EF	38	Fuse
EF	39	Fuse
EF	40	Fuse

Symbol	Name	Remarks
PC	1	Relay for compressor
PC	2	Relay for compressor
PC	3	Relay for compressor
PC	4	Relay for compressor
PC	5	Relay for compressor
PC	6	Relay for compressor
PC	7	Relay for compressor
PC	8	Relay for compressor
PC	9	Relay for compressor
PC	10	Relay for compressor
PC	11	Relay for compressor
PC	12	Relay for compressor
PC	13	Relay for compressor
PC	14	Relay for compressor
PC	15	Relay for compressor
PC	16	Relay for compressor
PC	17	Relay for compressor
PC	18	Relay for compressor
PC	19	Relay for compressor
PC	20	Relay for compressor
PC	21	Relay for compressor
PC	22	Relay for compressor
PC	23	Relay for compressor
PC	24	Relay for compressor
PC	25	Relay for compressor
PC	26	Relay for compressor
PC	27	Relay for compressor
PC	28	Relay for compressor
PC	29	Relay for compressor
PC	30	Relay for compressor
PC	31	Relay for compressor
PC	32	Relay for compressor
PC	33	Relay for compressor
PC	34	Relay for compressor
PC	35	Relay for compressor
PC	36	Relay for compressor
PC	37	Relay for compressor
PC	38	Relay for compressor
PC	39	Relay for compressor
PC	40	Relay for compressor

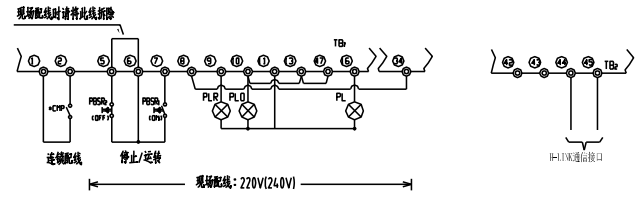
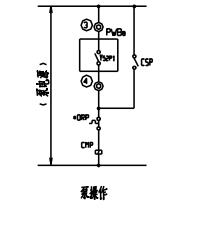
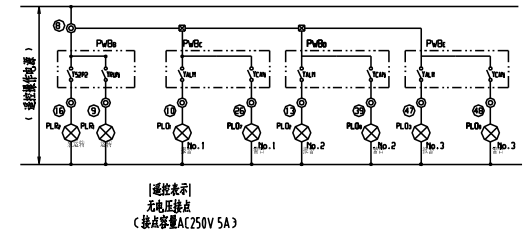

16. DIP Switch Setting

MODELS: RCUF45AZY1 ~ RCUF450AZY1
RCUF45AZPY1 ~ RCUF450AZPY1

TYPE MODELS	PWBa (Setting)	PWBb (Setting)	PWBc (Setting)	PWBo (Setting)	PWBe (Setting)
RCUF45AZY1 RCUF50AZY1 RCUF60AZY1 RCUF45AZPY1 RCUF50AZPY1					
RCUF60AZPY1					
RCUF90AZY1 RCUF90AZPY1 RCUF100AZY1 RCUF100AZPY1 RCUF120AZY1 RCUF180AZPY1 RCUF200AZY1 RCUF200AZPY1 RCUF220AZY1 RCUF320AZPY1-1 RCUF240AZY1 RCUF320AZPY1-2 RCUF270AZY1-2 RCUF400AZY1-3 RCUF420AZY1-3					
RCUF120AZPY1 RCUF240AZPY1 RCUF320AZPY1-3 RCUF360AZPY1					
RCUF150AZY1 RCUF135AZPY1 RCUF180AZY1 RCUF150AZPY1 RCUF270AZY1-1 RCUF270AZPY1 RCUF300AZY1 RCUF300AZPY1 RCUF330AZY1 RCUF405AZPY1 RCUF360AZY1 RCUF420AZPY1 RCUF400AZY1-1 RCUF450AZPY1 RCUF400AZY1-2 RCUF420AZY1-1 RCUF420AZY1-2 RCUF450AZY1					

Table 1

Mark	8	9	Compressor
DSW1	ON	OFF	50HP
	OFF	ON	60HP

Distributed By:

Specifications in this catalogue are subject to change without notice in order that HITACHI may bring the latest innovations to their customers.

URL: <http://www.jci-hitachi.com/ga>

Johnson Controls–Hitachi Wanbao Air-conditioning(Guangzhou)Co., Ltd.

© 2017 Johnson Controls–Hitachi Wanbao Air-conditioning(Guangzhou)Co., Ltd.

Printed in China No: Z0011912-2018-C